

ROCKY FLATS SITE REGULATORY CONTACT RECORD

Purpose: Soil Disturbance Review Plan (SDRP) for Regrading the East Perimeter Channel (EPC) and Associated Diversion Berms at the Original Landfill (OLF)

Contact Record Approval Date: November 22, 2013

Site Contact(s)/Affiliation(s): Scott Surovchak, U.S. Department of Energy (DOE); Rick DiSalvo, S.M. Stoller Corporation (Stoller); Linda Kaiser, Stoller; Jeremiah McLaughlin, Stoller

Regulatory Contact(s)/Affiliation(s): Carl Spreng, Colorado Department of Public Health and Environment (CDPHE); Vera Moritz, U.S. Environmental Protection Agency (EPA)

Date of Consultation Meeting: November 19, 2013. Continuation of consultation process that began September 18, 2013

Consultation Meeting Participants: Carl Spreng, CDPHE; Scott Surovchak, DOE; Rick DiSalvo, Stoller; Linda Kaiser, Stoller

Introduction: Rocky Flats Legacy Management Agreement (RFLMA) Contact Record (CR) 2013-02 documents the outcome of consultation between the DOE, CDPHE and EPA (the RFLMA parties) regarding DOE's response to localized distress cracking conditions on the OLF soil cover. These conditions were noted after the heavy precipitation event along the Front Range of Colorado from September 9 through September 16, 2013. The localized distress resulted in a reportable condition under RFLMA Attachment 2, Legacy Management Requirements. CR 2013-02 provides an evaluation plan and schedule for addressing the reportable condition, which included proposed regrading of the EPC and associated diversion berm ends to reduce slope grades in this area to improve soil cover stability and adding drainage features to further minimize the potential for infiltration of precipitation.

In accordance with the evaluation plan and schedule, drawings of the proposed grading and additional drainage features and an estimate of the time needed to complete the repairs to the OLF cover are to be submitted by November 25, 2013, for CDPHE review and approval. The schedule for completing the repairs will be dependent upon CDPHE's review and any changes that are required for DOE to obtain CDPHE approval of the final design.

Discussion: DOE and CDPHE met on November 19, 2013, to review DOE's proposed grading plan which results primarily in raising the EPC elevations but some areas will have slightly lower elevations. Figure 1 shows the location and anticipated aerial extent of the soil disturbance. A slotted drain pipe bedded in crushed rock was installed in the eastern end of diversion berm 4 as part of the initial response to the localized distress (see CR 2013-02) and this will be left in place.

The soil disturbance, filling and grading on the OLF cover is subject to the requirements of certain RFLMA institutional controls (ICs) as discussed below. An approved SDRP is required and the RFLMA parties agree that the preliminary design provides sufficient information for the SDRP for the proposed work.

Institutional Controls Evaluation: The soil disturbance work is subject to ICs 3 and 6. Table 1 recaps these ICs.

Table 1. Institutional Controls

IC 3	No grading, excavation, digging, tilling, or other disturbance of any kind of surface soils is permitted, except in accordance with an erosion control plan (including Surface Water Protection Plans submitted to EPA under the Clean Water Act) approved by CDPHE or EPA. Soil disturbance that will not restore the soil surface to preexisting grade or higher may not be performed without prior regulatory review and approval pursuant to the Soil Disturbance Review Plan in RFLMA Attachment 2.
	Objective: Prevent migration of residual surface soil contamination to surface water. Rationale: Certain surface soil contaminants, notably plutonium-239/240, were identified in the fate and transport evaluation in the Remedial Investigation as having complete pathways to surface water if disturbed. This restriction minimizes the possibility of such disturbance and resultant impacts to surface water. Restoring the soil surface to preexisting grade maintains the current depth to subsurface contamination or contaminated structures.
IC 6	Digging, drilling, tilling, grading, excavation, construction of any sort (including construction of any structures, paths, trails or roads), and vehicular traffic are prohibited on the covers of the Present Landfill and the Original Landfill, except for authorized response actions.
	Objective: Ensure the continued proper functioning of the landfill covers. Rationale: This restriction helps ensure the integrity of the landfill covers.

The required SDRP is in Attachment 1. The *Erosion Control Plan for Rocky Flats Property Central Operable Unit*, which has been approved by CDPHE and EPA, provides erosion control best management practices that meet the IC 3 requirements.

Resolution: CDPHE has reviewed information regarding the proposed soil disturbance and excavation and, after consultation with EPA, has approved the proposed activity and the proposed grading plan. CDPHE has determined that the proposed activity will not compromise or impair the function of the remedy or result in an unacceptable release or exposure to residual subsurface contamination. CDPHE has also determined that the proposed project meets the rationale and objectives of ICs 3 and 6.

The work will be conducted after CDPHE approval of the final grading design, but DOE will not conduct the approved soil disturbance until 10 calendar days after this CR is posted on the Rocky Flats website and stakeholders are notified of the posting in accordance with the RFLMA Public Involvement Plan. The work is planned to be conducted and completed in mid-December, 2013.

CDPHE approval of the final grading design, progress and the completion of the work will be reported by DOE in RFLMA quarterly and annual reports of surveillance and maintenance activities for the period(s) in which these activities occur.

Closeout of Contact Record: This Contact Record will be closed when the work is completed, post construction reseeding has been performed, and post construction erosion controls are in place.

Approval: Carl Spreng, CDPHE, approved this contact record.

Contact Record Prepared By: Rick DiSalvo

Distribution:

Carl Spreng, CDPHE
Scott Surovchak, DOE
Linda Kaiser, Stoller
Rocky Flats Contact Record File

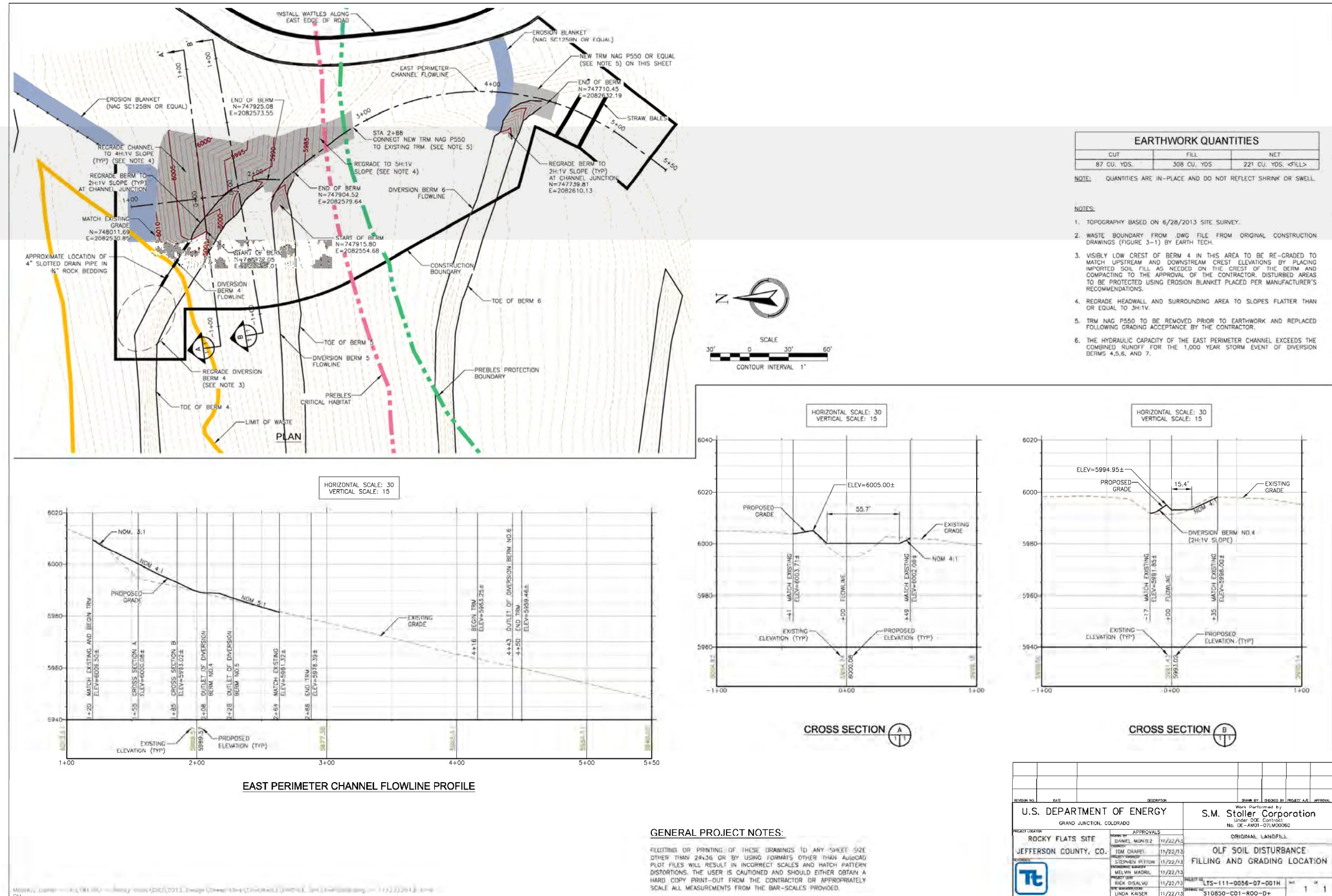

Figure 1. OLF Soil Disturbance, Filling and Grading Location

Rocky Flats Legacy Management Agreement (RFLMA) Soil Disturbance Review Plan

Proposed Project: Soil Disturbance Review Plan (SDRP) for Regrading the East Perimeter Channel (EPC) and Associated Diversion Berms at the Original Landfill (OLF)

This Soil Disturbance Review Plan provides information required by RFLMA Attachment 2, "Legacy Management Requirements," Section 4.1, "Soil Disturbance Review Plan," regarding the work proposed by DOE.

Description of the proposed project, including the purpose, the location, and the lateral and vertical extent of excavation.

The purpose of the proposed project is regrading of the EPC and associated diversion berm ends to reduce slope grades in this area to improve soil cover stability, and adding drainage features to further minimize the potential for infiltration of precipitation.

Contact Record 2013-03 Figure 1 shows the location and the lateral and vertical extent of the excavation and soil disturbance. The material (Rocky Flats Alluvium) (RFA) excavated from the cut areas will be used as fill in the fill areas. Additional clean RFA fill will be needed to complete the regrading. The additional clean RFA fill material will come from the Bestway, Inc. commercial gravel pit located directly west of the Central Operable Unit.

Information about any remaining subsurface structures in the vicinity of the proposed project.

There are no remaining subsurface structures in the vicinity of the proposed project. A buried natural gas line operated by Xcel Energy is in the utility easement corridor north of the OLF. The location and alignment of the natural gas line is well known and marked with signs. It is well outside of the soil disturbance area.

Information about any former Individual Hazardous Substance Sites (IHSSs), Potential Areas of Concern (PACs), or other known or potential soil or groundwater contamination in the vicinity of the proposed project.

The OLF is former IHSS 115. The OLF has a 2 foot thick soil cover over the location of the disposed waste materials and clean RFA fill surrounding the disposed materials for the placement and configuration of stormwater and seepwater management features. Limits of the waste area are shown in Contact Record 2013-03 Figure 1.

The project area is in the Upper Woman Drainage Exposure Unit (EU) evaluated in the Comprehensive Risk Assessment, in Appendix A of the RI/FS. The only contaminant of concern (COC) identified for this EU are benzo(a)pyrene and dioxins/furans for surface soil/surface sediment.

Dioxin/furan concentrations were converted to 2,3,7,8-tetrachlorodibenzo-p-dioxin (TCDD) toxicity equivalents (TEQs) for COC screening and risk characterization. Noncancer risks for benzo(a)pyrene and 2,3,7,8-TCDD (TEQ) were not evaluated because those COCs do not have noncancer toxicity values. Risks were calculated for benzo(a)pyrene and 2,3,7,8 TCDD (TEQ). The estimated Tier 1 total

excess lifetime cancer risk to the wildlife refuge worker (WRW) at the UWOEU is $8E-06$, and the Tier 2 risk is $4E-06$. It is important to note that the samples with the highest benzo(a)pyrene concentrations are located in an area that is now several feet beneath OLF cover. There were no COCs identified for subsurface soil or subsurface sediment in this EU.

The soil disturbance, regarding and drainage feature installation work will not intrude below the 2 foot thick soil cover within the limits of the waste location. The work primarily involves filling portions of the EPC to reduce the slope grades.

ROCKY FLATS SITE REGULATORY CONTACT RECORD

Purpose: East Trenches Plume Treatment System (ETPTS) media removal and reconfiguration for air stripper treatment

Contact Record Approval Date: January 21, 2014

Site Contact(s)/Affiliation(s): Scott Surovchak, U.S. Department of Energy (DOE); John Boylan, Rick DiSalvo, Linda Kaiser, David Ward, S.M. Stoller Corporation (Stoller)

Regulatory Contact(s)/Affiliation(s): Carl Spreng, Colorado Department of Public Health and Environment (CDPHE); Vera Moritz, U.S. Environmental Protection Agency (EPA)

Date of Consultation Meeting: December 5, 2013

Consultation Meeting Participants: Carl Spreng (CDPHE); Scott Surovchak (DOE); John Boylan, Rick DiSalvo, Linda Kaiser, George Squibb (Stoller)

Introduction: The ETPTS is designed to intercept and treat groundwater contaminated with volatile organic compounds (VOCs) from the East Trenches Plume. Routine maintenance of the ETPTS includes periodic removal of spent treatment media (zero-valent iron [ZVI] filings) and replacement with new ZVI. The ZVI media is contained in two, 12-foot-diameter cylindrical high-density polyethylene tanks, referred to as Cells 1 and 2. The ZVI is obtained from a source in Detroit, Michigan, and is trucked to the site for installation. Media removal and replacement is costly and labor intensive and requires the use of heavy construction equipment. The last ETPTS media replacement was performed in 2009, and based on historical operations of the ETPTS, routine media replacement is required approximately every 3 to 5 years. Routine maintenance to remove the spent ZVI media is planned for calendar year 2014.

VOC concentrations at the ETPTS surface water performance monitoring location POM2, located downstream of the system in South Walnut Creek, continue to meet Rocky Flats Legacy Management Agreement (RFLMA) Attachment 2, Legacy Management Requirements, Table 1, Surface Water Standards. However, because the ETPTS system effluent contains some VOC constituents at levels above RFLMA standards, the RFLMA Parties have consulted on ways to optimize treatment to further reduce the potential VOC contaminant load to surface water.

Contact Record 2012-02, "Improving treatment at the East Trenches Plume Treatment System (ETPTS) by adding an air stripper component," summarizes the RFLMA parties' consultation regarding installation of an air stripper in the ETPTS influent manhole to reduce VOC constituent concentrations upstream of Cells 1 and 2. This approach was based on the effective VOC removal by a pilot-scale air stripper installed in the Mound Site Plume Treatment System (MSPTS) effluent manhole in 2011, as discussed in Contact Record 2011-01, "Replace Mound

Site Plume Treatment System (MSPTS) media and maintain/repair discharge gallery.” The air stripper installation at the ETPTS influent manhole was completed in March 2013. Information on the status of operation and performance of the MSPTS and ETPTS air strippers is provided in RFLMA quarterly and annual site surveillance and maintenance reports. RFLMA contact records and site surveillance and maintenance reports are available on the Rocky Flats public website at http://www.lm.doe.gov/rocky_flats/Sites.aspx.

While the ETPTS air stripper has reduced influent VOC concentrations by approximately an order of magnitude, also resulting in a significant reduction in effluent concentrations after ZVI treatment, routine maintenance to remove the spent ZVI media is needed.

Discussion: While planning for the maintenance to remove the ZVI media, DOE also evaluated the potential for addition of a commercially available air stripper unit to dramatically reduce or eliminate ZVI media in the ETPTS. To implement this approach, the air stripper unit would be installed as one phase of the ZVI media removal project. The emptied Cells 1 and 2 would not be refilled with ZVI but would instead serve as air stripper influent and effluent equalization tanks. The ETPTS piping would be reconfigured to accommodate the air stripper. This approach would also maintain the future ability to use ZVI media in the original configuration if desired.

The DOE and CDPHE RFLMA project coordinators consulted on December 5, 2012, regarding preliminary identification of appropriately sized commercially available air stripper units. Preliminary information from potential vendors of air strippers indicates that some models could provide adequate VOC removal for the ETPTS effluent to meet RFLMA surface water standards. Preliminary information also indicates that these units could be run in a batch treatment mode using the power available from the existing solar photovoltaic (PV) system that was installed for the ETPTS influent manhole air stripper, or with only modest additional PV capacity. Batch treatment mode would involve operating the air stripper for several hours per day, rather than continuously, to treat ETPTS influent water stored in Cell 1 and discharge of treated water to Cell 2. Treated effluent in Cell 2 would then flow at a controlled rate to the discharge gallery.

Based on DOE’s evaluation of the ETPTS influent VOC concentration and flow rate, the amounts and types of VOCs that the air stripper will volatilize to the air will meet Colorado Air Quality Control Regulations exemption criteria for Air Pollutant Emission Notice (APEN) reporting thresholds and permitting.

The air stripper would be housed in a small enclosure for protection from the elements and sized and configured to allow maintenance of the air stripper components. The air stripper enclosure would be placed near Cells 1 and 2 in a location to minimize the disturbance of established vegetation or adverse impact to Preble’s meadow jumping mouse critical habitat.

Piping reconfiguration work, installation of the wiring from the current ETPTS PV power system, and the air stripper enclosure is expected to involve soil disturbance that would require a RFLMA Soil Disturbance Review Plan, as provided in RFLMA Attachment 2, Section 4.1.

Resolution: It was agreed that DOE will prepare engineering designs for the reconfiguration and installation of a commercial air stripper unit, to be completed based on DOE's identification of an appropriate commercially available unit after interaction with potential vendors is completed. It is estimated that the engineering designs would be completed around the end of January 2014.

The RFLMA parties will consult in a timely manner on proceeding with the ETPTS reconfiguration for air stripper treatment to allow further planning and implementation as part of the ETPTS ZVI media removal project. Approval of the reconfiguration and of any required Soil Disturbance Review Plan for the work will be documented in a subsequent contact record.

Closeout of Contact Record: This contact record will be closed when consultation on the ETPTS reconfiguration project engineering design is completed, and the RFLMA parties determine whether or not to implement the project.

Resolution: Carl Spreng, CDPHE, approved this CR.

Contact Record Prepared by: Rick DiSalvo and John Boylan

Distribution:

Carl Spreng, CDPHE
Scott Surovchak, DOE
Linda Kaiser, Stoller
Rocky Flats Contact Record File

ROCKY FLATS SITE REGULATORY CONTACT RECORD

Purpose: Minor Modification of *Rocky Flats Legacy Management Agreement (RFLMA)* Attachment 2, “Legacy Management Requirements.”

Contact Record Approval Date: January 30, 2014

Site Contact(s)/Affiliation(s): Scott Surovchak, U.S. Department of Energy (DOE); Linda Kaiser, S.M. Stoller Corporation (Stoller); Rick DiSalvo, Stoller; David Ward, Stoller

Regulatory Contact(s)/Affiliation(s): Carl Spreng, Colorado Department of Public Health and Environment (CDPHE); Vera Moritz, U.S. Environmental Protection Agency (EPA)

Date of Consultation Meeting: January 16, 2014

Consultation Meeting Participants: Carl Spreng, CDPHE; Vera Moritz, EPA; Scott Surovchak, DOE; Linda Kaiser, Stoller; Rick DiSalvo, Stoller

Introduction: In accordance with RFLMA Attachment 2, Section 5.1, “Monitoring Surface Water,” DOE certified to CDPHE and EPA that as of September 29, 2013 WOMPOC on Woman Creek and as of September 28, 2013 WALPOC on Walnut Creek had been functioning as Points of Compliance (POCs) for 2 years. Therefore, surface water monitoring locations GS01 on Woman Creek and GS03 on Walnut Creek ceased being RFLMA POCs. The only Woman Creek POC is now WOMPOC, and the only Walnut Creek POC is now WALPOC, both inside the Central Operable Unit (COU).

For background information on the changes to the POC locations, see Contact Record 2010-04, “[RFLMA] Attachment 2: Modification to Revise Monitoring Points” and Contact Record 2012-03 “Minor Modification of [RFLMA] Attachment 1, ‘Site Map,’” and RFLMA Attachment 2, “Legacy Management Requirements.”

The RFLMA parties agree that RFLMA Attachment 2 should be modified to remove GS01 and GS03 from text, tables, and figures for clarity and simplicity.

Pursuant to RFLMA paragraph 66, DOE and CDPHE do not consider these items to constitute a significant change from existing requirements of RFLMA, and this contact record provides public notice of the proposed minor modifications. DOE will submit the modifications to CDPHE and EPA for review and approval pursuant to RFLMA paragraph 65.

The specific minor modifications are described in more detail below.

Discussion: RFLMA Attachment 2 text to be deleted is shown in single-line strikethrough, and new text is in bold. Modifications to tables and figures are summarized.

1. Section 5.1, “Monitoring Surface Water”

...

- Points of Compliance (POCs): Located in Woman and Walnut Creeks at the downstream Central OU boundary. These locations are used to demonstrate compliance with the surface-water standards in Table 1 and are labeled WOMPOC and WALPOC respectively. ~~WALPOC, which replaced former POCs GS08 and GS11 on September 28, 2011, and WOMPOC, which replaced former POC GS31 on September 9, 2011, will also replace GS03 and GS01 respectively upon DOE notification to EPA and CDPHE certifying that WALPOC and WOMPOC have been functioning as POCs for at least 2 years. EPA or CDPHE may extend the 2-year period by requiring DOE to submit a modification to this attachment in accordance with RFLMA paragraph 65 if either determines that such modification is necessary to ensure protection of human health and the environment.~~

2. In Table 2, “Water Monitoring Locations and Sampling Criteria,” the rows for locations GS01 and GS03 will be deleted.

3. Table 2, footnote 5

~~Results for POCs are evaluated using Figure 5. POCs GS01 and GS03 will be replaced by WALPOC and WOMPOC per Section 5.1.~~

4. In Figure 1, “Water Monitoring at Rocky Flats: RFLMA,” locations GS01 and GS03 will be deleted.

5. Figure 1 notes

~~WALPOC and WOMPOC will replace POC locations GS01 and GS03 as described in Section 5.1~~

6. Figure 5, “Points of Compliance”, footnote 1

Calculated values for determining Reportable Condition and exceedances of remedy performance standards at POCs.

- Reportable conditions (according to Section 6.0):
 - plutonium, americium, uranium, nitrate** → 30-day average²
- Reportable Conditions and evaluation of compliance with remedy performance standards in Table 1:
 - plutonium, americium, uranium, nitrate** → 12-month rolling average³ for POCs inside COU; 30-day average for GS01 and GS03.

Closeout of Contact Record: This contact record will be closed when the minor modifications to RFLMA Attachment 2 are approved.

Resolution: Carl Spreng, CDPHE, approved this contact record.

Contact Record Prepared by: Rick DiSalvo and David Ward

Distribution:

Carl Spreng, CDPHE

Scott Surovchak, DOE

Linda Kaiser, Stoller

Rocky Flats Contact Record File

ROCKY FLATS SITE REGULATORY CONTACT RECORD

Purpose: Minor modification to the March 2008 Present Landfill (PLF) Monitoring and Maintenance Plan (M&M Plan)

Contact Record Approval Date: February 18, 2014

Site Contact(s)/Affiliation(s): Scott Surovchak, U.S. Department of Energy (DOE); Rick DiSalvo, S.M. Stoller Corporation (Stoller); Linda Kaiser, Stoller; Jeremiah McLaughlin, Stoller; David Ward, Stoller

Regulatory Contact(s)/Affiliation(s): Carl Spreng, Colorado Department of Public Health and Environment (CDPHE); Vera Moritz, U.S. Environmental Protection Agency (EPA)

Date of Consultation Meeting: Initial consultation on October 16, 2012, and documented in Contact Record (CR) 2012-03, with follow-on consultation on March 13 and August 26, 2013

Consultation Meeting Participants: Carl Spreng, CDPHE; Vera Moritz, EPA; Scott Surovchak, DOE; John Boylan, Stoller; Rick DiSalvo, Stoller; Linda Kaiser, Stoller; George Squibb, Stoller; Jody Nelson, JGMS, Inc.

Introduction: A minor modification to the *Rocky Flats Legacy Management Agreement* (RFLMA) Attachment 2, "Legacy Management Requirements" (RFLMA Attachment 2), was approved by CDPHE and EPA on February 21, 2013. The scope of the minor modification is described in RFLMA Contact Record 2012-03.

As part of the minor modification, RFLMA Attachment 2, Table 3, "Present and Original Landfill Inspection and Maintenance Requirements," was modified to remove landfill-specific vegetation and inspection requirements as recommended in the third 5-year review report. Landfill vegetation meets success criteria, and it will be monitored and managed under the site-wide vegetation and revegetation plans.

The RFLMA Attachment 2 modification also included, among other things, updates to maps to reflect the surface water configuration after breaching the dams for the Pond A-3 and the PLF Pond in 2012. The dam breach project is discussed in CR 2011-07. Prior to this modification, RFLMA Attachment 2 maps reflected the dam breach for Ponds A-1, A-2, and B-1 through B-4 completed in 2009, as discussed in CR 2008-02.

As discussed in CR 2012-03, minor modifications to the Original Landfill and PLF M&M Plans for vegetation monitoring were to be proposed. This contact record is for the PLF M&M Plan modification.

In addition to the vegetation monitoring requirements, several other items are proposed in this modification, as follows:

- Update to Figure 1–2, “PLF Site Map,” which shows the location of the PLF within the Central Operable Unit (COU), to reflect the COU surface water configuration after completion of the dam breach projects in 2009 and 2012.
- Update to Figure 2–1, “PLF Surface Features,” to reflect the PLF Pond dam breach. The historic subsurface asbestos disposal location at the northeast end of the PLF cover will also be added to Figure 2–1 for reference.
- Update to Figure 5–1, “PLF Seep Treatment System,” to reflect the PLF Pond (labeled as the East Landfill Pond) dam breach. Figure 5–1 will also show the RFLMA sampling location identified as NNG01, which replaced the sampling location identified as PLFPONDEFF “Pond Sample Location,” as discussed in RFLMA Contact Record 2010-04.
- Changes to Appendix A, “Present Landfill Inspection Forms” to remove the vegetation inspection form and to delete the figure, “PLF Inspections,” which is redundant to Figure 2–1.

Several editorial changes and clarifications will be included in the PLF M&M Plan minor modification, as described in more detail below.

Pursuant to RFLMA paragraph 66, DOE, CDPHE, and EPA do not consider these items to constitute a significant change from existing requirements of RFLMA, and this contact record shall be used to provide public notice of the proposed minor modifications. DOE will submit the proposed modifications to CDPHE and EPA for review, and CDPHE may approve modifications to RFLMA attachments pursuant to RFLMA paragraph 65.

Text Changes: PLF M&M Plan text that is proposed to be deleted is shown in single-line strikethrough, and new text is shown in underline. Proposed modifications to figures are summarized in the Introduction, above.

1. Section 1.0 “Introduction”

This Monitoring and Maintenance Plan and Post-Closure Plan (M&M Plan) applies to the Present Landfill (PLF) (Individual Hazardous Substance Site [IHSS] 114) at the Rocky Flats Site (Rocky Flats). The PLF M&M Plan was approved in 2006 and was modified in 2008. This PLF M&M Plan ~~is a~~ incorporates a minor modification of the ~~original~~ PLF M&M Plan, ~~approved in May 2006~~ as described further in this section, below.

...

~~The May 2006 PLF M&M Plan referenced RFCA in certain sections. This modified M&M Plan is based on the outcome of consultation in accordance with RFLMA consultative process as documented in Regulatory Contact Record 2007-08, which was approved December 21, 2007. Therefore, this modified PLF M&M Plan revises the original PLF M&M Plan text as appropriate to recognize the implementation of the remedy under RFLMA. It also incorporates changes in inspection frequencies, completion of certain monitoring requirements that now may be phased out, clarification of vegetation inspection schedules and completion criteria, as anticipated in the original PLF M&M Plan.~~

The 2008 PLF M&M Plan modification and this modification were based on the outcome of consultation in accordance with RFLMA consultative process as documented in RFLMA Contact Record (CR) 2007-08, approved December 21, 2007, and CR 2014-02, approved (insert approval date here).

...

2. Section 1.1 “Purpose”

The PLF M&M Plan is designed to meet the following objectives:
(The following abbreviation is used in the material in this section: Present Landfill Treatment System [PLFTS].)

....

3. Present the PLFTS ~~and East Landfill Pond~~ Environmental Monitoring Plan (Section 5.0).

....

3. Section 1.3 “Site Operations”

...The PLF eventually consumed the West Landfill Pond; the earthen dam for the PLF Pond (also known as the East Landfill Pond) was breached in 2012 as described in CR 2011-07 is still present.

4. Section 2.1 “Topography”

... Perimeter drainage channels were built to control surface water run-on and runoff and are sloped to drain to the east of the PLF below the ~~East Landfill~~ former PLF Pond dam. ...

5. Section 2.2 “Hydrology”

... On the northern side of the PLF, the western portion of the perimeter channel runs under a perimeter road through a culvert and east into a natural drainage that eventually joins the No Name Gulch drainage ~~below~~ (east of) the ~~East Landfill~~ former PLF Pond dam. The northeastern portion of the channel empties into the same natural drainage that eventually joins No Name Gulch ~~below the East Landfill Pond dam~~. On the southern side of the PLF, the perimeter channel runs eastward ~~above the East Landfill Pond~~ and drops into the No Name Gulch drainage ~~below the dam~~ (Figure 2-1).

...

A diversion berm constructed at the top of the east slope directs surface water from the cover away from the east face and into the perimeter channels. ~~These channels and diversion berms limit runoff into the East Landfill Pond.~~

~~The East Landfill Pond covers approximately 2.5 acres. Recharge to the pond occurs from direct precipitation, groundwater discharge, PLFTS effluent, and surface water runoff from the surrounding hillslopes, including surface water discharge from the two riprap channels~~

~~constructed on the east face of the PLF. Groundwater discharge is likely limited because of the relatively low hydraulic conductivity of the underlying weathered bedrock. At the discretion of DOE, the outlet valve in the dam may be left in the open position to limit the Pond water level, resulting in a maximum surface water area of approximately 0.8 acre; or the valve may be closed to increase the associated wetland vegetation. Pond discharge via the emergency overflow spillway will only occur if and when the operations are changed or there is an abnormal condition.~~

6. Section 2.5.5, “Former East Landfill Pond”

~~The dam for the East Landfill Pond (also referred to as the PLF Pond) was breached in 2012 and the area was filled and contoured to improve riparian habitat and to configure the No Name Gulch drainage to the approximate conditions prior to construction of the dam. will remain and receive treated water from the PLFTS and surface water from the east face and surrounding hillsides, as well as precipitation falling directly into the Pond. Monitoring of the Pond in No Name Gulch is discussed in Section 5.0.~~

7. Section 3.5,” Vegetation”

~~... Vegetation inspections will ensure that vegetation on the PLF cover is established properly. Maintenance of the cover vegetation will be consistent with the Revegetation Plan (DOE 2005a 2009) and the Vegetation Management Plan (DOE 2006b 2012) for site-wide vegetation management.~~

8. Section 3.5.1 “Monitoring Locations and Procedures”

~~Vegetation at the PLF will be monitored by visual inspection by traversing the cover and visually inspecting for the health of the vegetation and for unwanted vegetation such as weeds. In addition, the vegetation at the PLF will be monitored annually as described in the Revegetation Plan. Once the success criteria listed below (from the Revegetation Plan) have been met, and quantitative vegetation monitoring will be has been discontinued. The major goals of the plan are:~~

~~Quantitative grassland success criteria:~~

- ~~1. A minimum of 30 percent relative foliar cover of live desired species (seeded native species and/or non-seeded native species).~~
- ~~2. A minimum of 60 percent total ground cover comprised of litter cover, current year live vegetation basal cover, and rock cover.~~
- ~~3. A minimum of 50 percent of the seeded native species will be present at the revegetation site.~~
- ~~4. No single species will contribute more than 45 percent of the relative foliar cover (except in areas where dominance by a single species is appropriate for long-term wildlife and habitat management objectives).~~

~~...~~

9. Section 5.0 “Present Landfill Seep and ~~East Landfill Pond~~ Environmental Monitoring Plan” (The following abbreviation is used in the material in this section: data quality objective [DQO].)

... Effluent from the PLFTS eventually flows to the ~~East Landfill Pond~~ No Name Gulch. This section presents the monitoring plan for the PLFTS ~~influent and effluent as well as the East Landfill Pond~~, as required by the DQO process, if PLFTS effluent exceeds RFLMA Attachment 2, Table 1, “Surface Water Standards.”

10. Section 5.1 “Purpose and Requirements”

The ~~PLF Seep and East Landfill Pond~~ Monitoring Plan is implemented to determine surface water quality impacts of the PLF. ...

11. Section 5.2 “Data Quality Objectives”

... ~~PLFTS influent, effluent, and East Landfill Pond (when required) monitoring~~ Monitoring results will be evaluated in accordance with RFLMA Attachment 2, Figure 11, “Groundwater Treatment Systems,” which incorporates the DQO process.

12. Section 5.3 “Sample Locations”

... ~~If East Landfill Pond sampling is required as discussed in Sections 5.1 and 5.2, a sample will be collected near the pond discharge location~~ In addition, sampling at NNG01 (Figure 5-1) may be required in accordance with RFLMA Attachment 2, Figure 11, “Groundwater Treatment Systems,” if PLFTS effluent exceeds RFLMA Attachment 2, Table 1, “Surface Water Standards.”

13. Section 5.6 “Reporting and Schedule”

PLFTS and ~~East Landfill Pond~~ NNG01 sampling results will be included in the quarterly and annual reports specified in RFLMA Attachment 2, Section 7.0, “Periodic Reporting Requirements.” ...

14. Section 6.1 “Reporting”

The annual PLF monitoring report, including inspection results, repairs, groundwater monitoring data, PLFTS monitoring data, and ~~East Landfill Pond~~ NNG01 monitoring data if applicable, will be submitted as part of the RFLMA annual report. ... The annual PLF monitoring report will include at a minimum: ...

- All inspection forms/reports for the year, ~~including vegetation information~~; ...
- Tables with ~~East Landfill Pond~~ NNG01 sampling results if applicable;
- Figures with groundwater monitoring points, ~~East Landfill Pond monitoring points~~ NNG01, and location(s) of problems and/or repairs; and
- Groundwater and seep/PLFTS/~~East Landfill Pond~~ NNG01 water sampling forms, as appropriate.

...

Closeout of Contact Record: This contact record will be closed when the PLF M&M Plan minor modification is approved.

Resolution: Carl Spreng, CDPHE, approved this contact record.

Contact Record Prepared by: Rick DiSalvo

Distribution:

Carl Spreng, CDPHE

Scott Surovchak, DOE

Vera Moritz, EPA

Linda Kaiser, Stoller

Rocky Flats Contact Record File

ROCKY FLATS SITE REGULATORY CONTACT RECORD

Purpose: Approval of the installation and operation of an air stripper and the associated *Rocky Flats Legacy Management Agreement* (RFLMA) Soil Disturbance Review Plan as part of the reconfiguration of the East Trenches Plume Treatment System (ETPTS).

Contact Record Approval Date: February 19, 2014

Site Contact(s)/Affiliation(s): Scott Surovchak, U.S. Department of Energy (DOE); John Boylan, David Ward, Linda Kaiser, S.M. Stoller Corporation (Stoller)

Regulatory Contact(s)/Affiliation(s): Carl Spreng, Colorado Department of Public Health and Environment (CDPHE); Vera Moritz, U.S. Environmental Protection Agency

Introduction: Contact Record 2014-01, “East Trenches Plume Treatment System (ETPTS) media removal and reconfiguration for air stripper treatment,” summarizes the RFLMA parties’ consultation and decision to use an air stripper to treat groundwater contaminated with volatile organic compounds (VOCs) from the East Trenches Plume. The current ETPTS would be reconfigured for the installation and operation of a commercial air stripper. Air stripping for the removal of VOCs has been demonstrated effective at both the ETPTS and the Mound Site Plume Treatment System (MSPTS). Information on the status of operation and performance of the MSPTS and ETPTS air strippers is provided in RFLMA quarterly and annual site surveillance and maintenance reports. RFLMA contact records and site surveillance and maintenance reports are available on the Rocky Flats public website at http://www.lm.doe.gov/rocky_flats/Sites.aspx.

Contact Record 2014-01 documented that the next step would be for DOE to prepare the engineering design for the reconfiguration and installation of a commercial air stripper unit with enclosure, to be completed based on DOE’s identification of an appropriate commercially available unit after interaction with potential vendors is completed. The final approval of the reconfiguration and of any required Soil Disturbance Review Plan for the work would be documented in a subsequent contact record. The final engineering design was completed at the end of January 2014, and this Contact Record 2014-04 provides the final approval of the ETPTS reconfiguration, based on the information below.

Air Stripper Operation: The ETPTS reconfiguration project will replace the zero-valent-iron based treatment media with a commercial air stripper. The reconfigured system will operate in the following manner. Collected groundwater will be treated in batches: untreated influent will be routed from the groundwater intercept trench to original treatment Cell 1 (Influent Tank, the western high-density polyethylene [HDPE] tank). Each day, this collected water will be pumped from this influent tank to the new commercial air stripper, and treated effluent from this air stripper will drain to original treatment Cell 2 (Effluent Tank, eastern HDPE tank). Under normal conditions, the air stripper will turn on at a preset time each morning and process water that has

accumulated since the previous day. It will turn off when the water level drops below a set threshold, and remain off until the next morning. The treated effluent will be pumped from this effluent tank to the discharge gallery at a slower rate. This operation is depicted in Attachment 1.

Electrical Power and Air Stripper Enclosure: Treatment, pumping, and other processes will be accomplished using electrical power from the existing solar/battery facility in the conex adjacent to the ETPTS influent manhole, with four additional solar panels installed to help boost the power. The air stripper will be installed within a new enclosure to be built on top of one of the existing vaults at the ETPTS (next to the two HDPE tanks), which will simplify maintenance and operations by making the air stripper more easily accessible—the enclosure will not be a confined space, and will provide adequate room to operate and perform the necessary activities. Situating the enclosure atop an existing vault will take advantage of the geothermal from the vault.

ETPTS Operations During Construction: The existing air stripper within the influent manhole will be operated for as long as possible while the various construction activities are performed. This will continue to reduce contaminant concentrations in system influent by approximately 90 percent before the water is released to the ETPTS discharge gallery. There will be a short transition period (when final electrical modifications and related tasks are completed) during which this air stripper will no longer be operating and the new unit is not yet ready to operate. During this transition period, the influent water that is intercepted by the trench will be managed in the trench to minimize any influent water being routed directly to the discharge gallery.

Construction Excavation and Soil Disturbance Review Plan: The work will include excavation to approximately 6 to 8 feet below ground surface to install the enclosure footing, reconfigure the piping, and install electrical conduit. A copy of the design drawing showing the plan view of the existing configuration and the new enclosure, piping, and electrical is included as Attachment 2.

This excavation work will exceed the 3-foot depth limit specified by RFLMA institutional control (IC) 2 (RFLMA, Attachment 2, Table 4, Control 2). Therefore, the procedures require preapproval.

Furthermore, IC 3 (RFLMA, Attachment 2, Table 4, Control 3) stipulates that soil disturbance must be in accordance with the CDPHE-approved Erosion Control Plan and that the soil surface must be restored to the preexisting grade after any soil-disturbance activity has occurred.

The objective of the ICs is to maintain the current depth to subsurface contamination or contaminated structures. As discussed below, the proposed work achieves the CDPHE risk management policy goal.

Excavation will be reduced to the extent feasible, and soils will be returned to approximately the preexisting grade. Any excess soils from the excavation—after the foundation for the new enclosure, associated piping, and electrical are installed—will be used in the immediate area to reduce the potential for ponding and enhance drainage away from the influent and effluent tanks and enclosure. In addition, any leftover soil will be spread in areas where additional soils may be

used to facilitate revegetation (e.g., in the former roadway south of and adjacent to the former Pond B-4 dam). The best management practices in the *Erosion Control Plan for Rocky Flats Property Central Operable Unit* DOE-LM/1497-2007 (July 2007) will also be implemented to provide erosion controls for the construction area so that run-on and runoff will be minimized.

Water from precipitation in the excavation that may impact the construction work, or that accumulates in the treatment cells during the work, will be pumped to the ground.

CDPHE has requested that the following information related to ICs be included in contact records for soil excavation:

1) Provide information about any remaining subsurface structures in the vicinity so that the minimum cover assumption will not be violated (or state that there are none if that is the case).

The work is at the ETPTS. Except for ETPTS-related components, there are no other subsurface structures in the immediate vicinity. The westernmost portions of the electrical and data conduits will be installed at grade, and therefore will not impact the tops of the buried HDPE panels that are present along the downgradient side of the ETPTS interceptor trench. These conduits will be buried in a trench as they run eastward to the vicinity of the new enclosure, but this trench will be much shallower than the buried pipe that routes water from the influent manhole to the influent tank.

2) Provide information about any former IHSSs/PACs (Individual Hazardous Substance Sites/Potential Areas of Concern) or other known soil or groundwater contamination in the vicinity (or state that there is no known contamination).

The East Trenches Plume is upgradient of the ETPTS. There are no former IHSSs or PACs in the vicinity of the excavation area.

3) Resurvey any new surface established in subsurface soil, unless sufficient existing data is available to characterize the surface (or state that the excavated soil will be replaced and the original contours restored).

When the ETPTS reconfiguration project is completed, the surrounding soil will be generally consistent with the existing grade, with some very minor improvements to facilitate drainage and prevent ponding around the influent and effluent tanks and the new enclosure.

DOE and CDPHE RFLMA Project Coordinators agreed to proceed with the installation and operation of the ETPTS reconfigured air stripper as described above.

Resolution: Carl Spreng, CDPHE, approved this contact record.

Closeout of Contact Record: This contact record will be closed when the work is completed and post-construction revegetation and erosion controls are in place.

Contact Record Prepared by: David Ward and John Boylan

Distribution:

Carl Spreng, CDPHE

Scott Surovchak, DOE

Vera Moritz, EPA

Linda Kaiser, Stoller

Rocky Flats Contact Record File

TRENCH
MANHOLE

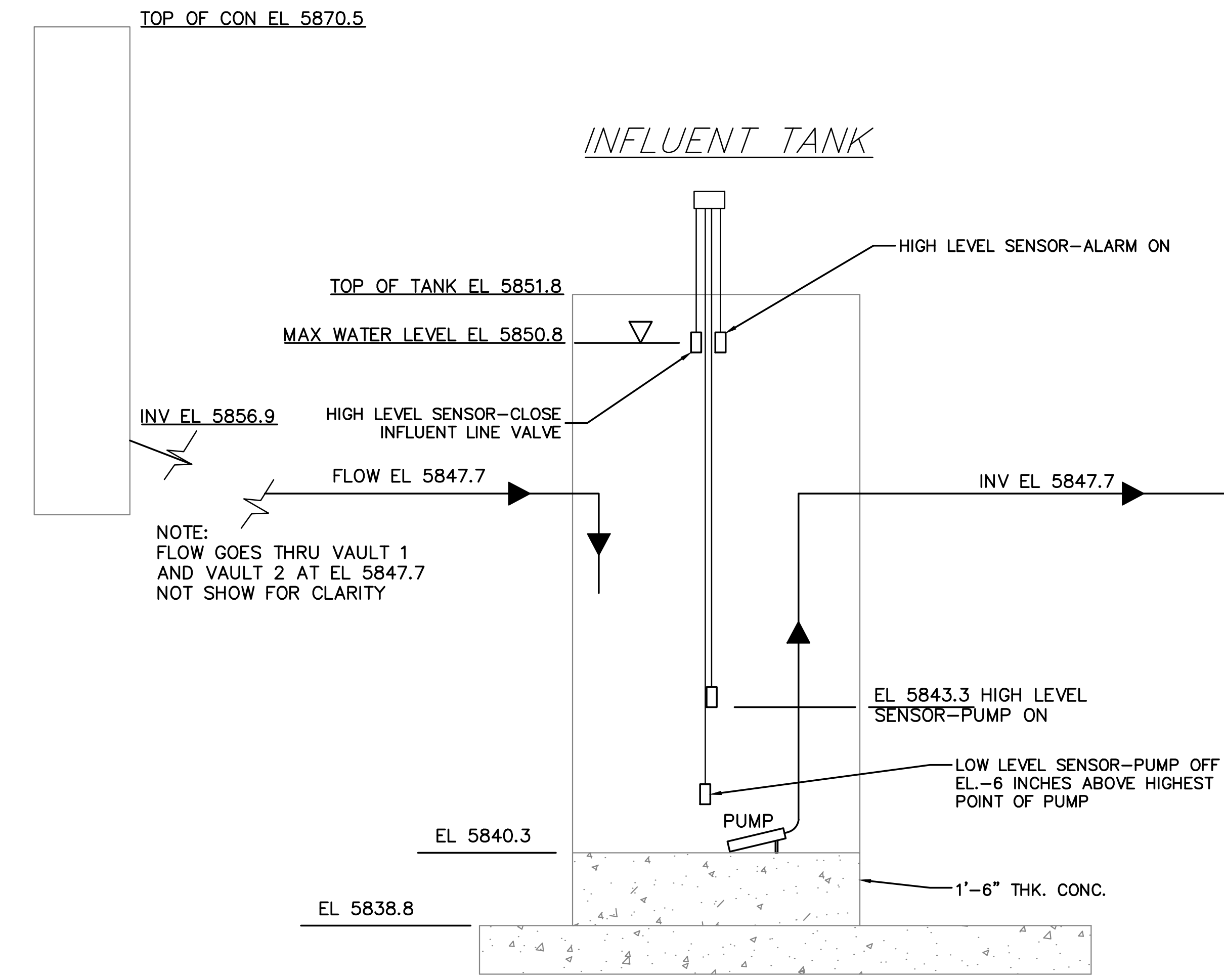

AIR STRIPPER
ENCLOSURE

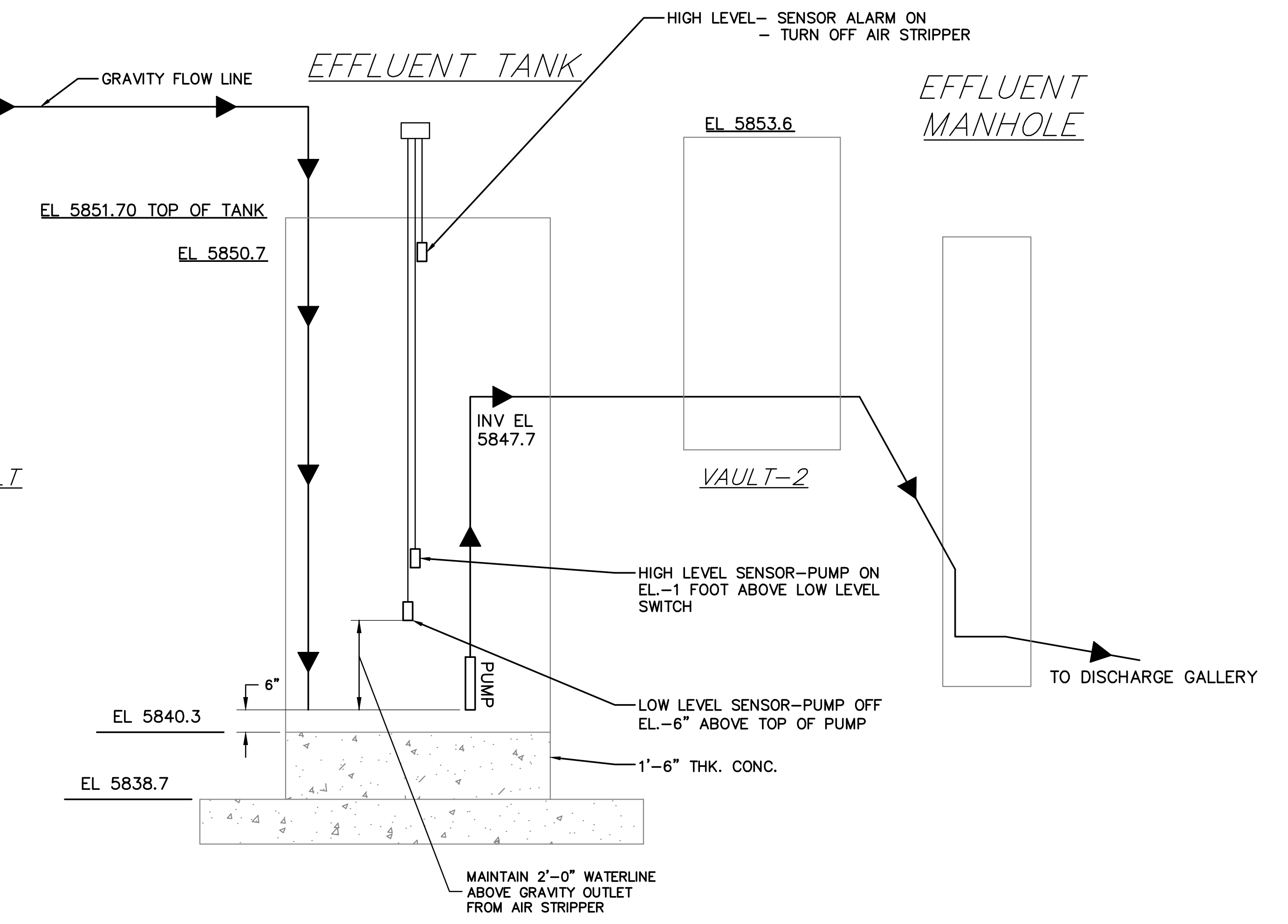
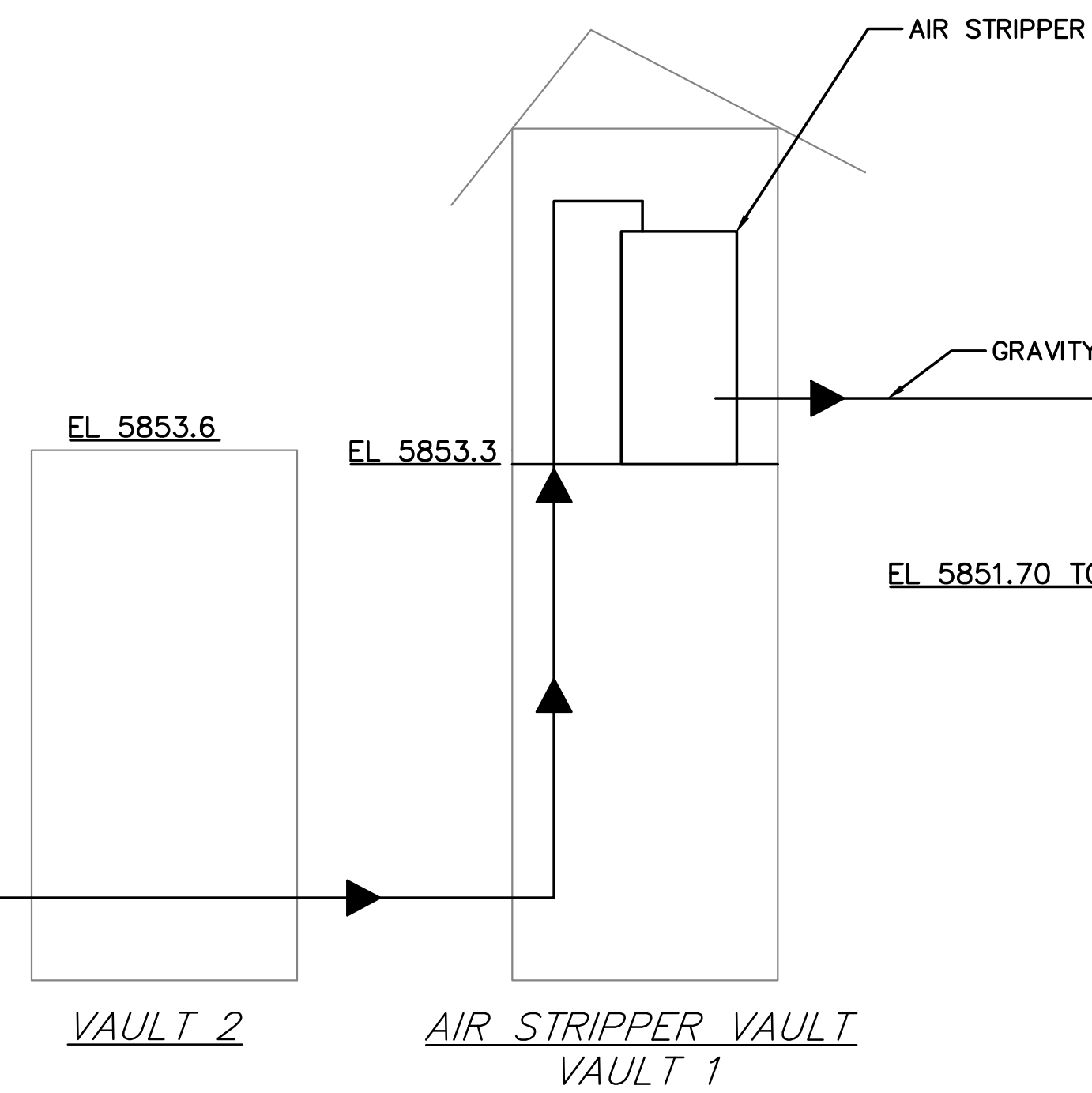

SYSTEM CONTROL DIAGRAM
SCALE: VERT. 1" = 2.0' (TANKS ONLY)

- NOTES:
1. TOP OF TANK ELEVATIONS ARE ACTUAL TANK RIM, NOT TOP OF HDPE LINER.
2. SENSORS:
GEMS SENSORS, MODEL LS-750. CONTRACTOR SUPPLIED.

FINAL DESIGN

REDUCED DRAWING SIZES
ARE NOT TO SCALE

REVISION NO.	DATE	DESCRIPTION	DRAWN BY	CHECKED BY	PROJECT A/E	APPROVAL
U.S. DEPARTMENT OF ENERGY GRAND JUNCTION, COLORADO			Work Performed by S.M. Stoller Corporation Under DOE Contract No. DE-AM01-07LM00060			
ROCKY FLATS SITE JEFFERSON COUNTY, CO			APPROVALS DESIGNED BY: S. PITTON 1/30/14 DRAWN BY: S. PITTON 1/30/14 PROJECT ENGINEER: J. Pitton 1/30/14 ENGINEERING MANAGER: M. MADRILL 1/30/14		ETPTS RECONFIGURATION 2014	
SYSTEM CONTROL DIAGRAM			PROJECT LEAD: J. BOYLAN 1/30/14 SITE MANAGER/LEAD: L. KAISER 1/30/14		PROJECT NO: LTS-111-0056-10-006C DRAWING NO: S11032-R00-C03-D+	

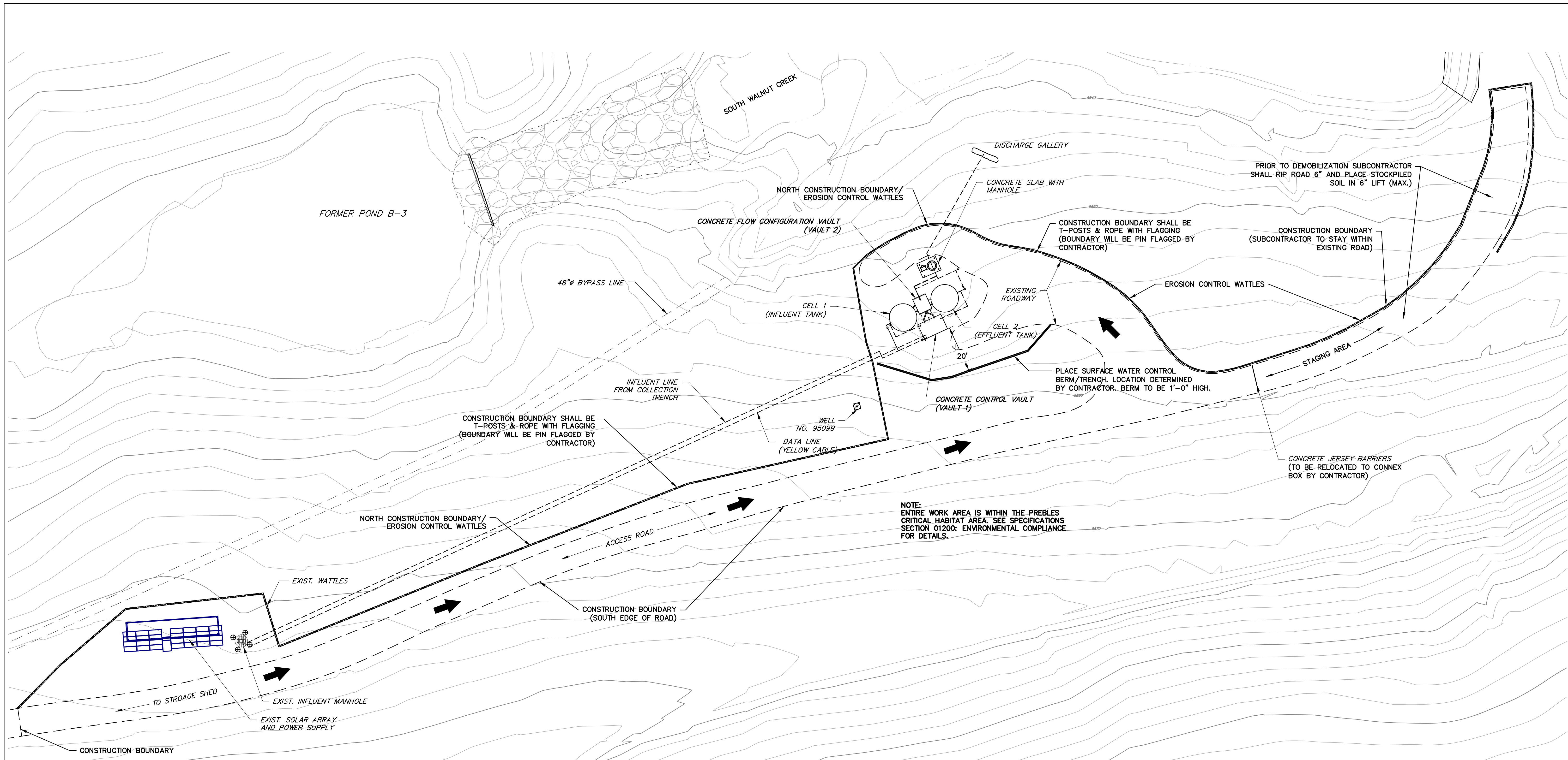

NOTE:
ENTIRE WORK AREA IS WITHIN THE PREBLES
CRITICAL HABITAT AREA. SEE SPECIFICATIONS
SECTION 01200: ENVIRONMENTAL COMPLIANCE
FOR DETAILS.

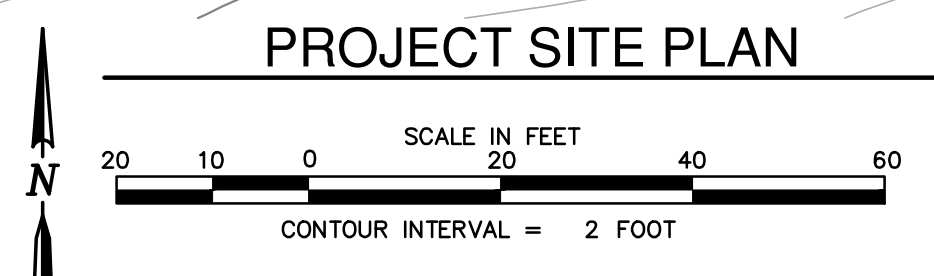

- REVEGETATION/EROSION CONTROL NOTES:
1. CONTRACTOR WILL PROVIDE WATTLES AND STAKES.
 2. PRE-CONSTRUCTION INSTALLATION OF WATTLES FOR EROSION CONTROL SHALL BE CONDUCTED BY SUBCONTRACTOR.
 3. SUBCONTRACTOR IS RESPONSIBLE FOR MAINTENANCE/REPAIR OF EROSION CONTROLS THROUGHOUT THE DURATION OF THE PROJECT.
 4. REVEGETATION WILL BE CONDUCTED BY THE CONTRACTOR.
 5. ALL STOCKPILED SOILS SHALL REMAIN INSIDE THE EROSION CONTROLS AND SHALL HAVE WATTLES PLACED AROUND THEIR PERIMETER.
 6. ALL REMAINING STOCKPILED SOIL SHALL BE PLACED IN ROAD (EAST END OF STAGING AREA) AND SPREAD IN 6" LIFTS (MAX) AT THE CONCLUSION OF CONSTRUCTION.
 7. NO PROJECT ACTIVITIES OR STOCKPIILING OF MATERIALS/SOILS ARE ALLOWED OUTSIDE THE CONSTRUCTION BOUNDARY OR EQUIPMENT.

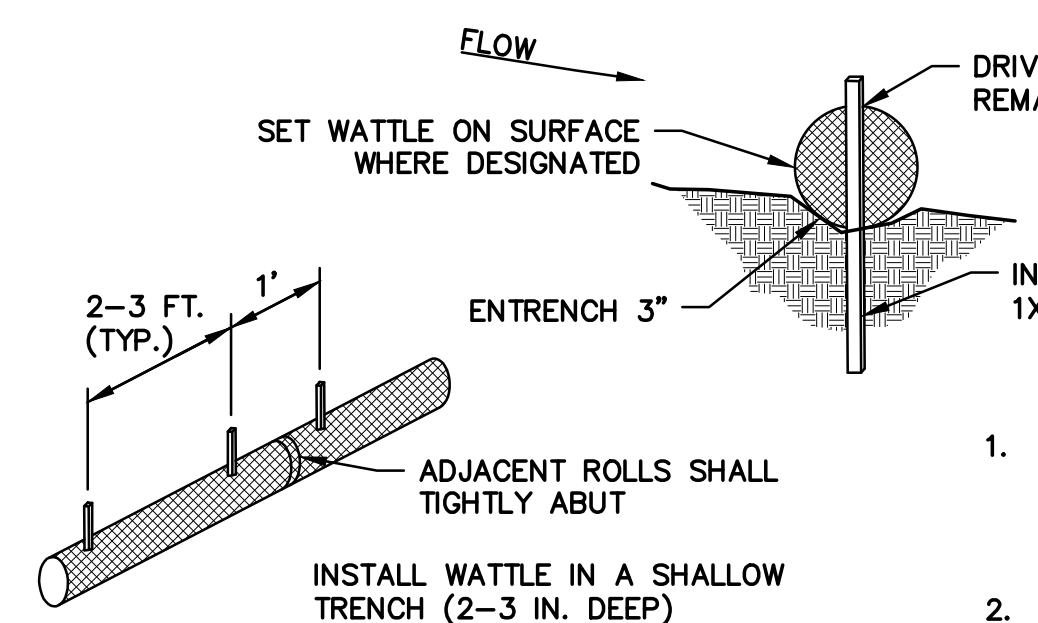

1. BEGIN AT THE LOCATION WHERE THE WATTLE IS TO BE INSTALLED BY EXCAVATING A 2-3" (5-7.5CM) DEEP X 9" (22.9 CM) WIDE TRENCH ALONG THE CONTOUR OF THE SLOPE. EXCAVATED SOIL SHOULD BE PLACED UP-SLOPE FROM THE ANCHOR TRENCH.
2. PLACE THE WATTLE IN THE TRENCH SO THAT IT CONTOURS TO THE SOIL SURFACE. COMPACT SOIL FROM THE EXCAVATED TRENCH AGAINST THE WATTLE ON THE UPHILL SIDE. ADJACENT WATTLES SHOULD TIGHTLY ABUT.
3. SECURE THE WATTLE WITH 18"-24" (45.7-61 CM) STAKES EVERY 2-3' AND WITH A STAKE ON EACH END. STAKES SHOULD BE DRIVEN THROUGH THE MIDDLE OF THE WATTLE LEAVING AT LEAST 2-3" (5-7.5 CM) OF STAKE EXTENDING ABOVE THE WATTLE. STAKES SHOULD BE DRIVEN PERPENDICULAR TO SLOPE FACE.
4. WATTLES SHALL BE 9"Ø SEDIMAX-SW9.

STRAW WATTLE INSTALLATION GUIDE
NTS

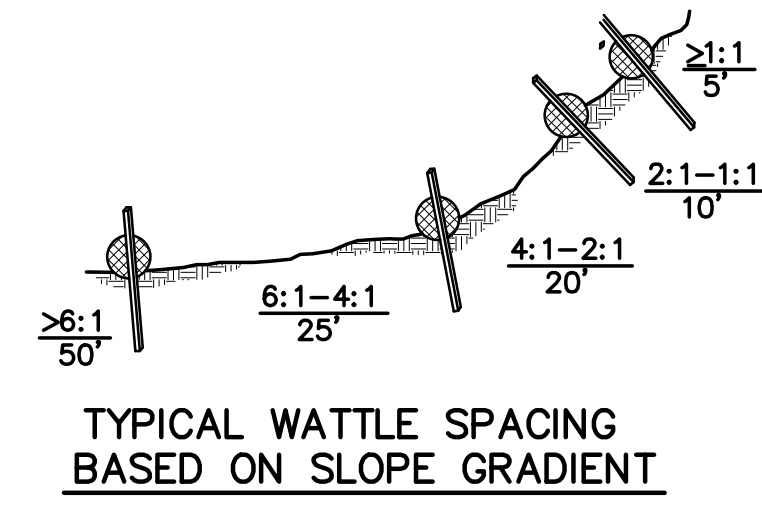

FINAL DESIGN

REDUCED DRAWING SIZES
ARE NOT TO SCALE

U.S. DEPARTMENT OF ENERGY GRAND JUNCTION, COLORADO		Work Performed by S.M. Stoller Corporation Under DOE Contract No. DE-AM01-07LM00060	
PROJECT LOCATION ROCKY FLATS SITE JEFFERSON COUNTY, CO		ETPTS RECONFIGURATION 2014	
APPROVALS		PROJECT NO. LTS-111-0056-10-006C	
DESIGN BY S. PITTON	1/30/14	DATE	1/30/14
DRONEER S. PITTON	1/30/14	PROJECT ENGINEER	J. Pitton
PROJECT ENGINEER S. Pitton	1/30/14	ENGINEERING MANAGER M. MADRILL	1/30/14
PROJECT LEAD J. BOYLAN	1/30/14	PROJECT LEAD L. KAISER	1/30/14
DRAWING NO. S11028-R00-C01-D+		SHT. 2 OF 18	

ROCKY FLATS SITE

REGULATORY CONTACT RECORD 2014-05

Purpose: Reportable condition for evaluation purposes for uranium at Point of Compliance WALPOC.

Contact Record Approval Date: April 8, 2014

Site Contact(s)/Affiliation(s): Scott Surovchak, U.S. Department of Energy (DOE); George Squibb, Linda Kaiser, David Ward, S.M. Stoller Corporation (Stoller)

Regulatory Contact(s)/Affiliation(s): Carl Spreng, Colorado Department of Public Health and Environment (CDPHE); Vera Moritz, U.S. Environmental Protection Agency (EPA)

Date of Consultation Meeting: February 18, 2014

Consultation Meeting Participants: Carl Spreng, CDPHE; Vera Moritz, EPA; Scott Surovchak, DOE; George Squibb, Linda Kaiser, David Ward, Stoller

Discussion: A reportable condition that occurred at surface water Point of Compliance (POC) WALPOC at the Rocky Flats Site was based on an evaluation of validated analytical results for uranium from the composite sample collected during the period from 11:39 a.m. on December 18, 2013, to 1:27 p.m. on January 16, 2014.

The evaluation was performed in accordance with *Rocky Flats Legacy Management Agreement* (RFLMA) Attachment 2, Figure 5, “Points of Compliance,” and resulted in a calculated 30-day average concentration for uranium of 16.9 micrograms per liter ($\mu\text{g/L}$) on December 18, 2013. This amount exceeds the RFLMA-applicable Table 1 standard of 16.8 $\mu\text{g/L}$. Validated results were received on February 3, 2014 and notification to the regulatory agencies and the public—in accordance with RFLMA Attachment 2, Figure 5—was made by e-mail on February 13, 2014. Representatives of the regulatory agencies and DOE met on February 18, 2014, to discuss this result and develop a path forward.

Pursuant to RFLMA Attachment 2, Section 6.0, “Action Determinations,” a reportable condition necessitates the following actions:

- DOE must submit a plan and schedule for an evaluation to address the condition within 30 days of receiving the validated data for the reportable condition.
- DOE will consult with CDPHE and EPA to determine if mitigating actions are necessary.
- The objective of the consultation will be to determine a course of action (if necessary) to address the reportable condition and to ensure that the remedy remains protective.
- The results of the consultation will be documented in contact records, in written correspondence, or both.

This contact record documents DOE’s consultation with CDPHE and EPA on February 18, 2014.

RFLMA Contact Record 2014-05

The RFLMA Parties agreed on the evaluation steps described below and agreed that no mitigating actions are necessary at this time, for the following reasons:

- The remedy remains protective. The remedy standard for total uranium at the WALPOC sampling location is the calculated 12-month rolling average. Using the most recent validated data, the calculated 12-month rolling average at WALPOC for total uranium on December 31, 2013, is 6.1 µg/L, well below the remedy performance standard of 16.8 µg/L.
- WALPOC has been a RFLMA monitoring location for roughly 2.5 years. During that period, the Site experienced one of its driest years (2012) and its wettest month (September 2013) according to precipitation data collected since 1990. Because uranium concentrations are influenced by changing environmental conditions, varying uranium concentrations at WALPOC are anticipated. While significant uranium concentration variability can be seen in both individual sample results and in the 30-day averages, the observed variability is not outside of anticipated ranges nor do these levels suggest the existence of a new source term.
- Although the recent result was above the Site standard of 16.8 µg/L, it remains well below the drinking water standard (i.e., the maximum contaminant level [MCL]) of 30 µg/L. While the MCL is not applied at the Site, the fact that the uranium concentration triggering this reportable condition was well below that level indicates that the remedy remains protective of human health and the environment.

However, the RFLMA Parties also agreed that further evaluation should be completed to help confirm the foregoing conclusions and to aid in developing future mitigating actions if they become necessary.

Plan and Schedule to Address the Reportable Condition: The RFLMA Parties agreed that steps described in this Contact Record shall serve as the plan and schedule for the evaluation.

The following steps have been or are being taken and will inform the evaluation.

- Measured concentrations of total uranium at WALPOC include both naturally occurring and anthropogenic uranium. Previous high-resolution isotopic uranium analyses for WALPOC show signatures that are between 76 and 80 percent naturally occurring uranium. Additional high-resolution isotopic uranium analysis on the most recent WALPOC samples is being conducted to determine the percentages of natural and anthropogenic uranium for comparison to the historical data. These samples include a split from the December 18, 2013, composite sample that triggered the reportable condition. Additional grab samples were collected on February 13, 2014, from WALPOC, Pond A-4, GS11 (Pond A-4 outlet), Pond B-5, and GS08 (Pond B-5 outlet). These samples will also be evaluated using high-resolution uranium analysis techniques.
- Split samples will continue to be collected from each flow-paced composite collected at WALPOC and held for possible high-resolution isotopic uranium analysis.
- Flow-paced composite samples routinely being collected at WALPOC will continue to be analyzed on a 2-week turnaround.
- A qualified geochemistry subcontractor with direct and applicable experience at the Rocky Flats Site is currently conducting an extensive evaluation of the fate and transport of uranium at the Site. The data collected throughout the Walnut Creek drainage for the fate and transport study will also be utilized in this WALPOC reportable condition evaluation.

The purpose of the study, as it relates to this reportable condition, is to evaluate variability in uranium concentrations—due to seasonal, hydrologic, geochemical, and geographic effects—through the collection of targeted analytical and field data. The study also incorporates the ongoing calculation of the percentages of natural uranium versus anthropogenic uranium in Walnut Creek.

The methods used for the study include assessing historical and current data, identifying patterns or correlations, and evaluating potential geochemical mechanisms that may contribute to the noted results. The study has also identified additional data needs; collection of these data is ongoing.

The study is scheduled to be completed in CY 2014.

- On February 26, 2014, DOE provided a split sample from the sample collected on January 16, 2014, to CDPHE for analysis of uranium at the State's Radiochemistry Laboratory.

DOE will report the results of this monitoring and of the subsequent evaluation in RFLMA quarterly and annual reports of surveillance and monitoring activities. This plan and schedule may be modified based on the outcome of RFLMA Party consultation related to the evaluation.

To keep the public informed, the outcome of continuing RFLMA Party consultation regarding the evaluation will be reported in RFLMA quarterly and annual reports of surveillance and monitoring activities or in subsequent contact records.

Resolution: Carl Spreng, CDPHE, approved this contact record.

Closeout of Contact Record: This contact record will be closed when the results from the evaluation have been transmitted to CDPHE or as the RFLMA Party consultation related to this evaluation directs.

Contact Record Prepared by: George Squibb and David Ward, Stoller

Distribution:

Carl Spreng, CDPHE
Scott Surovchak, DOE
Vera Mortiz, EPA
Linda Kaiser, Stoller
Rocky Flats Contact Record File

ROCKY FLATS SITE

REGULATORY CONTACT RECORD 2014-06

Purpose: Vinyl chloride results from the Present Landfill Treatment System (PLFTS) effluent triggered the consultative process.

Contact Record Approval Date: May 21, 2014

Site Contact(s)/Affiliation(s): Scott Surovchak, U.S. Department of Energy (DOE); George Squibb, Linda Kaiser, David Ward, The S.M. Stoller Corporation, a wholly owned subsidiary of Huntington Ingalls Industries (Stoller)

Regulatory Contact(s)/Affiliation(s): Carl Spreng, Colorado Department of Public Health and Environment (CDPHE); Vera Moritz, U.S. Environmental Protection Agency (EPA)

Date of Consultation Meeting: April 24, 2014

Consultation Meeting Participants: Carl Spreng, CDPHE; Vera Moritz, EPA; Scott Surovchak, DOE; Linda Kaiser, David Ward, Stoller

Discussion: As part of the Present Landfill closure, a passive seep interception and treatment system was installed to treat volatile organic compounds (VOCs) in landfill seep water and Groundwater Intercept System (GWIS) water. There are three sources of influent to the treatment system: two GWIS pipes and the Present Landfill seep. Effluent from the treatment system eventually flows to the former Landfill Pond area.

As required by the *Rocky Flats Legacy Management Agreement* (RFLMA) Attachment 2, Table 2, "Water Monitoring Locations and Sampling Criteria," the Present Landfill Treatment System (PLFTS) effluent monitoring requirements consist of routine quarterly sampling for VOCs, semivolatile organic compounds, and metals to evaluate remedy performance. In accordance with RFLMA Attachment 2, Figure 11, "Groundwater Treatment Systems," an exceedance of a surface-water standard at the PLFTS effluent monitoring location (PLFSYSEFF) triggers monthly effluent sampling to provide additional data for evaluation. If exceedances continue for three consecutive samples during the subsequent increased-frequency sampling period, sampling is triggered at location NNG01 (downstream of the former Landfill Pond area) for those constituents in question. Concurrently, consultation between the RFLMA parties takes place to determine whether a change in the remedy is required, if additional parameters need to be analyzed, or if a modification of the monitoring plan is warranted.

The routine quarterly effluent sample collected on 10/29/2013 (Table 1), showed a vinyl chloride concentration exceeding the practical quantitation limit (PQL) of 0.2 microgram per liter ($\mu\text{g/L}$) standard from the RFLMA Attachment 2, Table 1, "Surface Water Standards." Subsequent sampling at the increased frequency showed three consecutive vinyl chloride concentrations also exceeding the RFLMA PQL, which triggered sampling at location NNG01 and consultation.

The Site PQL of 0.2 µg/L is well below the drinking water standard (i.e., the maximum contaminant level of 2.0 µg/L).

NNG01 was sampled on 3/26/2014 (Table 2), and vinyl chloride was not detected.

A similar situation occurred in 2007. At that time, the RFLMA parties took no additional actions and the sampling protocol returned to the routine quarterly sampling at PLFSYSEFF.

The RFLMA parties have consulted regarding the results summarized in Tables 1 and 2 and have agreed to continue the RFLMA sampling protocol with no changes or additional actions.

Table 1. Present Landfill Treatment System Effluent (PLFSYSEFF): Summary of Analytical Results

Analyte	Sample Date	Result ^a	Units	RFLMA Attachment 2, PQL
Vinyl Chloride	10/29/2013	0.21	µg/L	0.20
	11/27/2013	0.29	µg/L	0.20
	1/21/2014	0.28	µg/L	0.20
	2/26/2014	0.21	µg/L	0.20

Notes: The initial result triggering monthly sampling is shown in **bold**. The routine quarterly samples are shown in italics.

^a All results are J qualified. "J qualified" means the analyte was positively identified. The associated numerical value is an estimated quantity.

Table 2. Former Landfill Pond Area Outflow (NNG01): Summary of Analytical Results

Analyte	Sample Date	Result ^a	Units	RFLMA PQL
Vinyl Chloride	3/26/2014	<0.10	µg/L	0.20

Notes: The 2/26/2014 PLFSYSEFF result (Table 1) was received on 3/24/2014, triggering sampling at NNG01.

^a The result is U qualified. "U qualified" means the analyte was not detected at a concentration greater than the method detection limit.

Resolution: Carl Spreng, CDPHE, approved this contact record.

Closeout of Contact Record: This contact record will be closed when it is posted on the Rocky Flats Site website.

Contact Record Prepared by: David Ward and George Squibb

Distribution:

Carl Spreng, CDPHE
 Scott Surovchak, DOE
 Vera Moritz, EPA
 Linda Kaiser, Stoller
 Rocky Flats Contact Record File

ROCKY FLATS SITE REGULATORY CONTACT RECORD 2014-07

Purpose: Abandonment of Sentinel well 88104 at the Rocky Flats Site, Colorado.

Contact Record Approval Date: July 21, 2014

Site Contact(s)/Affiliation(s): Scott Surovchak, U.S. Department of Energy (DOE); John Boylan, Linda Kaiser, David Ward, The S.M. Stoller Corporation, a subsidiary of Huntington Ingalls Industries (Stoller)

Regulatory Contact(s)/Affiliation(s): Carl Spreng, Colorado Department of Public Health and Environment (CDPHE); Vera Moritz, U.S. Environmental Protection Agency (EPA)

Date of Consultation Meeting: June 2, 2014

Consultation Meeting Participants: Carl Spreng, Walter Avramenko, CDPHE; Vera Moritz, EPA; Scott Surovchak, DOE; John Boylan, Linda Kaiser, David Ward, Jeremiah McLaughlin, George Squibb, Stoller; Jody Nelson, JGMS, Inc.

Discussion: Sentinel well 88104 casing is broken within the screened interval, approximately 10 feet below ground surface. This well monitors groundwater downgradient of former Building 881 (B881). The broken casing was observed during the second quarter 2014 sampling event, and it was noted that several feet of the well casing has filled with filter-pack sand. Site technical staff believes the damage was caused by movement of the soil on the hillside.

This condition and three primary response alternatives were discussed: (1) install a replacement well, (2) insert a smaller-diameter casing in the existing breached casing and continue to monitor this location until that inner casing also breaks, or (3) discontinue sampling and abandon the well. Recent data from well 88104 and the two closest wells that also monitor former B881, Evaluation well 88205 and Sentinel well 00797, were evaluated (see attached map for well locations).

The discussion included *Rocky Flats Legacy Management Agreement* (RFLMA) Attachment 2, Figure 8, "Sentinel Wells," flowchart which provides the evaluation protocols for Sentinel wells, including the "discontinue monitoring" criteria. Well 88104 meets one, but not both, exit criteria. Specifically, none of the analytes monitored at this well are represented by an 85th percentile concentration that exceeds RFLMA values (Sentinel well criterion #1)—in fact, the individual data are also below these values. On the other hand, the statistical trend in uranium, the constituent of interest that is most commonly detected in samples from this well, is neither decreasing nor indeterminate at this time (Sentinel well criterion #2). However, well 88104 is redundant considering the proximity of wells 88205 and 00797.

The following additional factors were evaluated to determine the appropriate course of action for breached well 88104:

- Sentinel wells 88104 and 00797 appear to be redundant due to the fact that: well 00797 is a short distance downgradient of well 88104. The objective of both of these Sentinel wells is to detect contaminant migration from the likely source area, former B881. Well 88104 is closer to this presumed source area than is well 00797, but well 00797 is close enough and properly positioned to detect contaminant migration toward surface water, particularly when combined with Evaluation well 88205.
- Evaluation well 88205 is located closer to former B881 than well 88104. (Well 88205 is located in the former parking lot, near the loading dock on the south end of the building; well 88104 is south of the road that was south of that parking lot.) Evaluation wells are intended to monitor source areas and help determine when monitoring of an area or plume can cease.
- Uranium concentrations in samples from well 88104 do not support any statistical trend that is 95% significant. However, an increasing trend of lower significance is suggested. Uranium concentrations in samples from well 00797 are on an increasing trend that has a 95% significance. Uranium concentrations in both wells are lower than the uranium threshold stated in RFLMA Figure 8 footnote: “Decisions related to uranium are based upon a 120 µg/L [micrograms per liter] threshold for AOC [Area of Concern] wells.”
- Samples from Sentinel well 88104 contain higher concentrations of uranium than do samples from Evaluation well 88205. However, high-resolution gamma spectrometry uranium analyses performed by Los Alamos National Laboratory (LANL) of samples from the original wells (88101 and 5187, respectively) prior to closure indicate that the uranium in the groundwater monitored by both wells is predominantly natural. A sample collected June 18, 2002, from well 88101 (later replaced by well 88104) contained a concentration of slightly more than 148 µg/L uranium that was characterized as 100.0% natural. A sample collected June 28, 2002, from well 5187 (later replaced by well 88205) contained approximately 13.2 µg/L of uranium that was characterized as 97.6% natural. Samples collected between June 1999 and June 2002 from two other wells in this area (abandoned wells 5287 and 5387) were also analyzed by LANL; of the six analyses from these additional wells, the uranium ranged from 98.6% to 100.0% natural.
- Samples collected from well 88205 have historically contained higher concentrations of volatile organic compounds (VOCs) than have samples from well 88104, which is consistent with the objectives of an Evaluation well (88205). VOCs concentrations in samples from well 88205 have been higher than the RFLMA Table 1, “Surface Water Standards,” concentrations on several instances. None of the VOCs detected in samples from well 88104 have been higher than RFLMA Table 1 standards, and the last reported detection of a VOC (through the end of 2013) was in 2010.
- Well 88104 is damaged. This damage is likely worsening; no damage was indicated in the fourth quarter of 2013, but during the second quarter of 2014 the broken 2-inch-diameter casing only allowed objects smaller than 1 inch in diameter to pass, and a significant portion of the well has filled with filter-pack sand. Restoring functionality to this well using an inner casing would be a temporary fix until the inner casing breaks. Given that well 88104 is redundant, resources required to replace it could be put to better uses. The groundwater monitoring network would continue to effectively monitor groundwater downgradient of former B881 if well 88104 was abandoned and not replaced.

Consistent with RFLMA Part 5, "Regulatory Approach," the RFLMA parties have determined that the above rationale is sufficient to abandon well 88104, in spite of not precisely meeting the RFLMA Attachment 2, Figure 8, "Sentinel Wells" Flowchart criteria. Therefore, well 88104 will be abandoned in place, per Volume 2 *Code of Colorado Regulations* 402-2, "Rules and Regulations for Water Well Construction, Pump Installation, Cistern Installation and Monitoring and Observation Hole/Well Construction." When RFLMA Attachment 2 is next revised, Table 2, "Water Monitoring Locations and Sampling Criteria," will be updated to remove well 88104.

The removal of this well will not result in a new intrusive activity below a depth of three feet, and therefore a Soil Disturbance Review Plan will not be required. The site staff will continue monitoring the B881 hillside for stability.

Resolution: Carl Spreng, CDPHE, approved this contact record.

Closeout of Contact Record: This contact record will be closed when the well is abandoned.

Contact Record Prepared by: John Boylan and David Ward

Distribution:

Carl Spreng, CDPHE
Scott Surovchak, DOE
Vera Mortiz, EPA
Linda Kaiser, Stoller
Rocky Flats Contact Record File

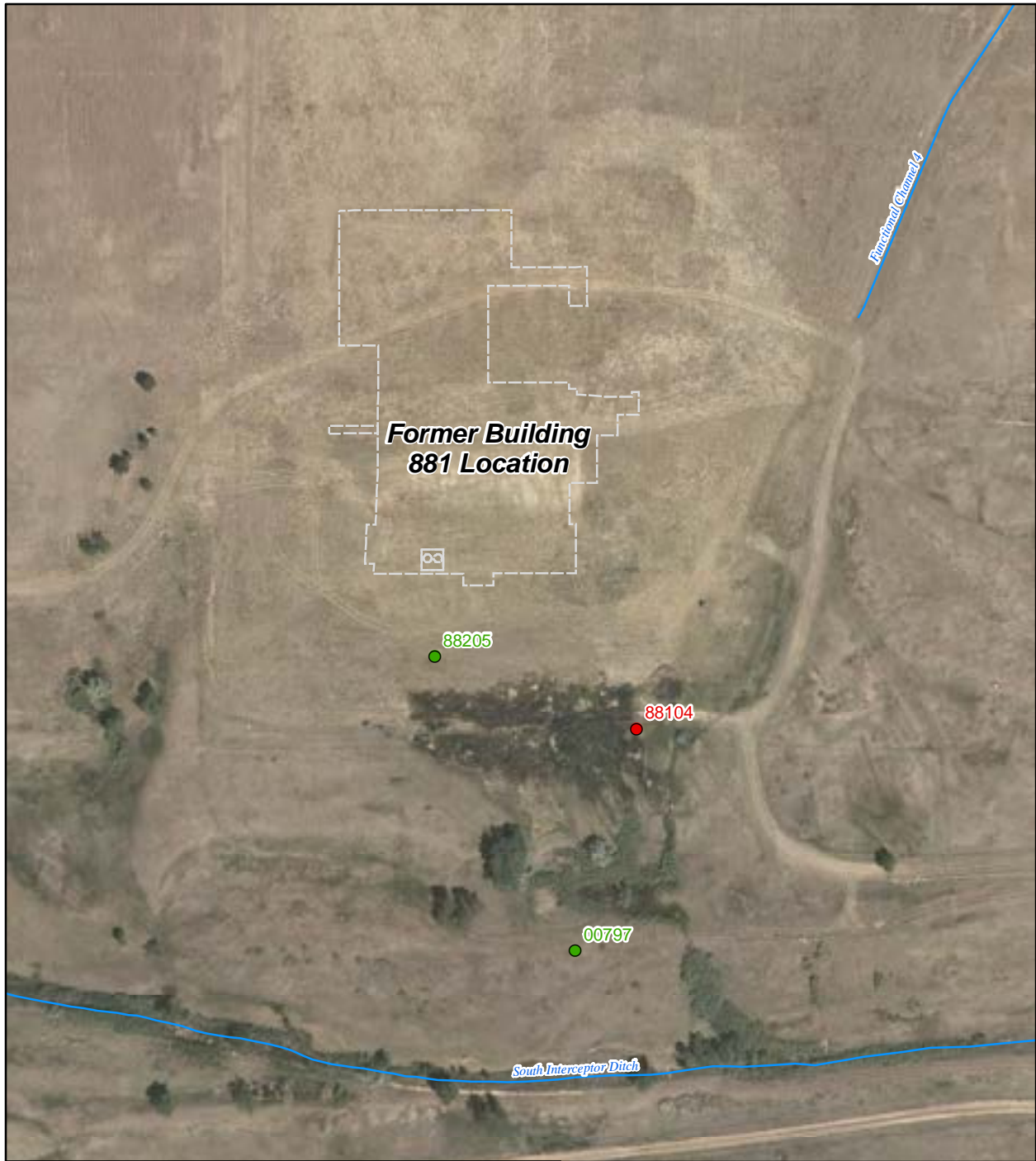

Legend <ul style="list-style-type: none"> ● Groundwater Monitoring Well to be Abandoned ● Groundwater Monitoring Well to Remain — Stream or Ditch 	 SCALE IN FEET 100 50 0 100 	U.S. DEPARTMENT OF ENERGY <small>GRAND JUNCTION, COLORADO</small>	<small>Work Performed by</small> S.M. Stoller Corporation <small>Under DOE Contract No. DE-AM01-07LM00060</small>
		RFLMA Groundwater Monitoring Downgradient of Former Building 881	

M:\LTS\111\0056\03\010\S11992\S1199200.mxd brownc 07/02/2014 10:08:42 AM

ROCKY FLATS SITE

REGULATORY CONTACT RECORD 2014-08

Purpose: Provide flexibility to the flow configuration at the Solar Ponds Plume Treatment System (SPPTS) as part of the ongoing optimization effort.

Contact Record Approval Date: July 18, 2014

Site Contact(s)/Affiliation(s): Scott Surovchak, U.S. Department of Energy (DOE); John Boylan, Linda Kaiser, David Ward, The S.M. Stoller Corporation, a subsidiary of Huntington Ingalls Industries (Stoller)

Regulatory Contact(s)/Affiliation(s): Carl Spreng, Colorado Department of Public Health and Environment (CDPHE); Vera Moritz, U.S. Environmental Protection Agency (EPA)

Discussion: The ability to alter the flow configuration between treatment components will support ongoing efforts to optimize the operation and effectiveness of the SPPTS at the Rocky Flats Site, Colorado. The existing piping between the treatment components will be modified to provide the needed flow-configuration flexibility. A hole approximately 8 feet × 8 feet and 6 feet deep will be excavated to access the existing piping and allow the installation of the new piping configuration. This excavation is entirely within the footprint of the Phase II and Phase III excavations and will only disturb the fill material in that area. Once the new piping configurations are complete, the excavation will be backfilled to the original grade with the excavated material.

The soil disturbance that occurs during the excavation of existing piping is subject to the requirements of certain *Rocky Flats Legacy Management Agreement* (RFLMA) institutional controls (ICs), as discussed below. An approved Soil Disturbance Review Plan (SDRP) is required and the RFLMA parties agree that Figure 1 provides sufficient information for the SDRP for the proposed work.

Institutional Controls Evaluation: The soil disturbance work is subject to ICs 3 and 6. Table 1 recaps these ICs.

Table 1. Institutional Controls

IC 3	No grading, excavation, digging, tilling, or other disturbance of any kind of surface soils is permitted, except in accordance with an erosion control plan (including Surface Water Protection Plans submitted to EPA under the Clean Water Act) approved by CDPHE or EPA. Soil disturbance that will not restore the soil surface to preexisting grade or higher may not be performed without prior regulatory review and approval pursuant to the Soil Disturbance Review Plan in RFLMA Attachment 2.
	Objective: Prevent migration of residual surface soil contamination to surface water. Rationale: Certain surface soil contaminants, notably plutonium-239/240, were identified in the fate and transport evaluation in the Remedial Investigation as having complete pathways to surface water if disturbed. This restriction minimizes the possibility of such disturbance and resultant impacts to surface water. Restoring the soil surface to preexisting grade maintains the current depth to subsurface contamination or contaminated structures.
IC 6	Digging, drilling, tilling, grading, excavation, construction of any sort (including construction of any structures, paths, trails or roads), and vehicular traffic are prohibited on the covers of the Present Landfill and the Original Landfill, except for authorized response actions.
	Objective: Ensure the continued proper functioning of the landfill covers. Rationale: This restriction helps ensure the integrity of the landfill covers.

The required SDRP is in Attachment 1. The *Erosion Control Plan for Rocky Flats Property Central Operable Unit*, approved by CDPHE and EPA, provides erosion control best management practices that meet the IC 3 requirements.

Resolution: CDPHE after reviewing information regarding the proposed soil disturbance and excavation and consultation with EPA, will approve, approve with modification or disapprove the proposed activity. CDPHE will determine if the proposed activity will not compromise or impair the function of the remedy or result in an unacceptable release or exposure to residual subsurface contamination. CDPHE will also determine if the proposed project meets the rationale and objectives of ICs 3 and 6.

The work will be conducted after CDPHE’s approval, but DOE will not conduct the approved soil disturbance until 10 calendar days after this contact record is posted on the Rocky Flats site’s website and stakeholders are notified of the posting in accordance with the RFLMA Public Involvement Plan. The work is planned to be conducted and completed in the summer of 2014.

Information regarding this excavation and piping installation will be reported in quarterly reports, annual reports, or both, depending on when the activities occur.

Closeout of Contact Record: This contact record will be closed when the new piping is installed, the excavation is backfilled, and any revegetation and erosion controls are in place.

Contact Record Prepared by: David Ward

Distribution:

Carl Spreng, CDPHE

Scott Surovchak, DOE

Vera Moritz, EPA

Linda Kaiser, Stoller

Rocky Flats Contact Record File



Figure 1. Location of Excavation for Piping Installation

**Rocky Flats Legacy Management Agreement (RFLMA)
Soil Disturbance Review Plan (SDRP)**

Proposed Project: SDRP for providing flexibility to the flow configuration at the Solar Ponds Plume Treatment System (SPPTS) as part of the ongoing optimization effort.

This SDRP provides information required by RFLMA Attachment 2, *Legacy Management Requirements*, Section 4.1, “Soil Disturbance Review Plan,” regarding the work proposed by DOE.

1) Description of the proposed project, including the purpose, the location, and the lateral and vertical extent of excavation.

The purpose of the proposed project is to improve flexibility in the operations of the SPPTS.

A hole approximately 8 feet x 8 feet and 6 feet deep will be excavated to access the existing piping that requires modification to provide the needed flexibility. Figure 1 in Contact Record 2014-08 shows the location of the excavation and soil disturbance. This excavation is within the existing footprint and fill materials of the Phase II and Phase III upgrades to the SPPTS.

2) Information about any remaining subsurface structures in the vicinity of the proposed project.

The work is at the SPPTS. Except for SPPTS-related components, there are no other subsurface structures in the immediate vicinity.

3) Information about any former Individual Hazardous Substance Sites (IHSSs), Potential Areas of Concern (PACs), or other known or potential soil or groundwater contamination in the vicinity of the proposed project.

The Solar Ponds Plume is upgradient of the SPPTS. There are no former IHSSs or PACs in the vicinity of the excavation area. The excavation is within fill materials from the Phase II and Phase III installations.

4) Resurvey any new surface established in subsurface soil, unless sufficient existing data is available to characterize the surface (or state that the excavated soil will be replaced and the original contours restored).

When the new piping configuration is installed at the SPPTS and the excavation is backfilled, the surrounding soil will be generally consistent with the existing grade.

ROCKY FLATS SITE

REGULATORY CONTACT RECORD 2014-09

Purpose: Soil Disturbance Review Plan (SDRP) Update for Regrading the East Perimeter Channel (EPC) at the Original Landfill (OLF)

Contact Record Approval Date: October 6, 2014

Site Contacts/Affiliations: Scott Surovchak, U.S. Department of Energy (DOE); Jeremiah McLaughlin, Linda Kaiser, David Ward, The S.M. Stoller Corporation, a wholly owned subsidiary of Huntington Ingalls Industries (Stoller)

Regulatory Contacts/Affiliations: Carl Spreng, Colorado Department of Public Health and Environment (CDPHE); Vera Moritz, U.S. Environmental Protection Agency (EPA)

Date of Consultation Meeting: August 5, 2014

Consultation Meeting Participants: Carl Spreng, CDPHE; Vera Moritz, EPA; Scott Surovchak, DOE; John Boylan, Linda Kaiser, David Ward, George Squibb, Stoller

Introduction: *Rocky Flats Legacy Management Agreement* (RFLMA) Contact Record (CR) 2013-02 documents the outcome of consultation between DOE, CDPHE, and EPA (the RFLMA parties) regarding DOE's response to localized distress-cracking conditions on the OLF soil cover. These conditions were noted after the heavy precipitation event along the Front Range of Colorado from September 9 through September 16, 2013. The localized distress resulted in a reportable condition under RFLMA Attachment 2, "Legacy Management Requirements." CR 2013-02 provides an evaluation plan and schedule for addressing the reportable condition, which included proposed regrading of the EPC and associated diversion berm ends to reduce slope grades in this area to improve soil cover stability and adding drainage features to further minimize the potential for infiltration of precipitation.

In accordance with the evaluation plan and schedule, CR 2013-03 was issued (approved November 22, 2013), providing the required SDRP and a discussion of the proposed regrading of the EPC and associated diversion berms. CDPHE approved the drawings of the proposed grading and additional drainage features on December 4, 2013, and DOE planned to complete the work in December 2013. However, because of the winter weather conditions, the soil was either frozen or too wet to complete the approved project, and the work was rescheduled to the summer of 2014, as reported in the *Rocky Flats, Colorado, Site Quarterly Report of Site Surveillance and Maintenance Activities First Quarter Calendar Year 2014*.

Cracking and slumping were noted on the east side of the EPC, outside the landfill boundary, in the first and second quarters of CY 2014 (before the work was scheduled to be performed). Therefore, DOE decided to reevaluate the design approved in December 2013 prior to implementing.

Discussion: DOE, CDPHE, and EPA met on August 5, 2014, to review the proposed update to the grading plan. The primary updates to the December 2013 grading plan are to cut back the ends of berms 4, 5, and 6 and taper the sides of the channel back to a more gradual slope. Figure 1 shows the location and anticipated aerial extent of the soil disturbance. The construction boundary is similar to the previous (December 2013) design, but soil disturbance is more extensive. There is a smaller area around the berm 4 flow line inside the “limit of waste” that will have new turf reinforcement material installed for erosion control. In October 2013 a slotted drainage pipe bedded in ¾-inch crushed drain rock was installed in the eastern end of diversion berm 4 as part of the initial response to the localized distress (see CR 2013-02), and this will be left in place. Another 4-inch slotted drainage pipe bedded in crushed drain rock will be installed between berm 5 and 6 to drain water from Seep #2/3 into the EPC. The excess soil will be distributed inside the COU as shown in Figure 2. No intrusive work will be performed within the waste footprint boundary.

The soil disturbance, filling, and grading on the OLF cover is subject to the requirements of RFLMA institutional controls (ICs) as discussed below. An approved SDRP is required, and the RFLMA parties agree that the preliminary design provides sufficient information for the SDRP for the proposed work.

Institutional Controls Evaluation: The soil disturbance work is subject to ICs 3 and 6. Table 1 recaps these ICs.

Table 1. Institutional Controls

IC 3	No grading, excavation, digging, tilling, or other disturbance of any kind of surface soils is permitted, except in accordance with an erosion control plan (including Surface Water Protection Plans submitted to EPA under the Clean Water Act) approved by CDPHE or EPA. Soil disturbance that will not restore the soil surface to preexisting grade or higher may not be performed without prior regulatory review and approval pursuant to the Soil Disturbance Review Plan in RFLMA Attachment 2.
	Objective: Prevent migration of residual surface soil contamination to surface water. Rationale: Certain surface soil contaminants, notably plutonium-239/240, were identified in the fate and transport evaluation in the Remedial Investigation as having complete pathways to surface water if disturbed. This restriction minimizes the possibility of such disturbance and resultant impacts to surface water. Restoring the soil surface to preexisting grade maintains the current depth to subsurface contamination or contaminated structures.
IC 6	Digging, drilling, tilling, grading, excavation, construction of any sort (including construction of any structures, paths, trails or roads), and vehicular traffic are prohibited on the covers of the Present Landfill and the Original Landfill, except for authorized response actions.
	Objective: Ensure the continued proper functioning of the landfill covers. Rationale: This restriction helps ensure the integrity of the landfill covers.

The required SDRP is in Attachment 1. The *Erosion Control Plan for Rocky Flats Property Central Operable Unit*, which has been approved by CDPHE and EPA, provides erosion control best management practices that meet the IC 3 requirements.

Resolution: CDPHE has review information regarding the proposed soil disturbance and excavation and, after consulting with EPA, has approved the proposed activity and the proposed grading plan. CDPHE has determined that the proposed activity will not compromise or impair

the function of the remedy or result in an unacceptable release or exposure to residual subsurface contamination. CDPHE has also determined that the proposed project meets the rationale and objectives of ICs 3 and 6.

DOE will not conduct the approved soil disturbance until 10 calendar days after this CR is posted on the Rocky Flats website and stakeholders are notified of the posting in accordance with the RFLMA Public Involvement Plan. The work is planned to be conducted and completed in late 2014.

DOE will report progress and the completion of the work in RFLMA quarterly and annual reports of surveillance and maintenance activities for the periods in which these activities occur.

Closeout of Contact Record: This Contact Record will be closed when the work is completed, post-construction reseeded has been performed, and post construction erosion controls are in place.

Contact Record Prepared by: David Ward

Distribution:

Carl Spreng, CDPHE
Vera Moritz, EPA
Scott Surovchak, DOE
Linda Kaiser, Stoller
Rocky Flats Contact Record File

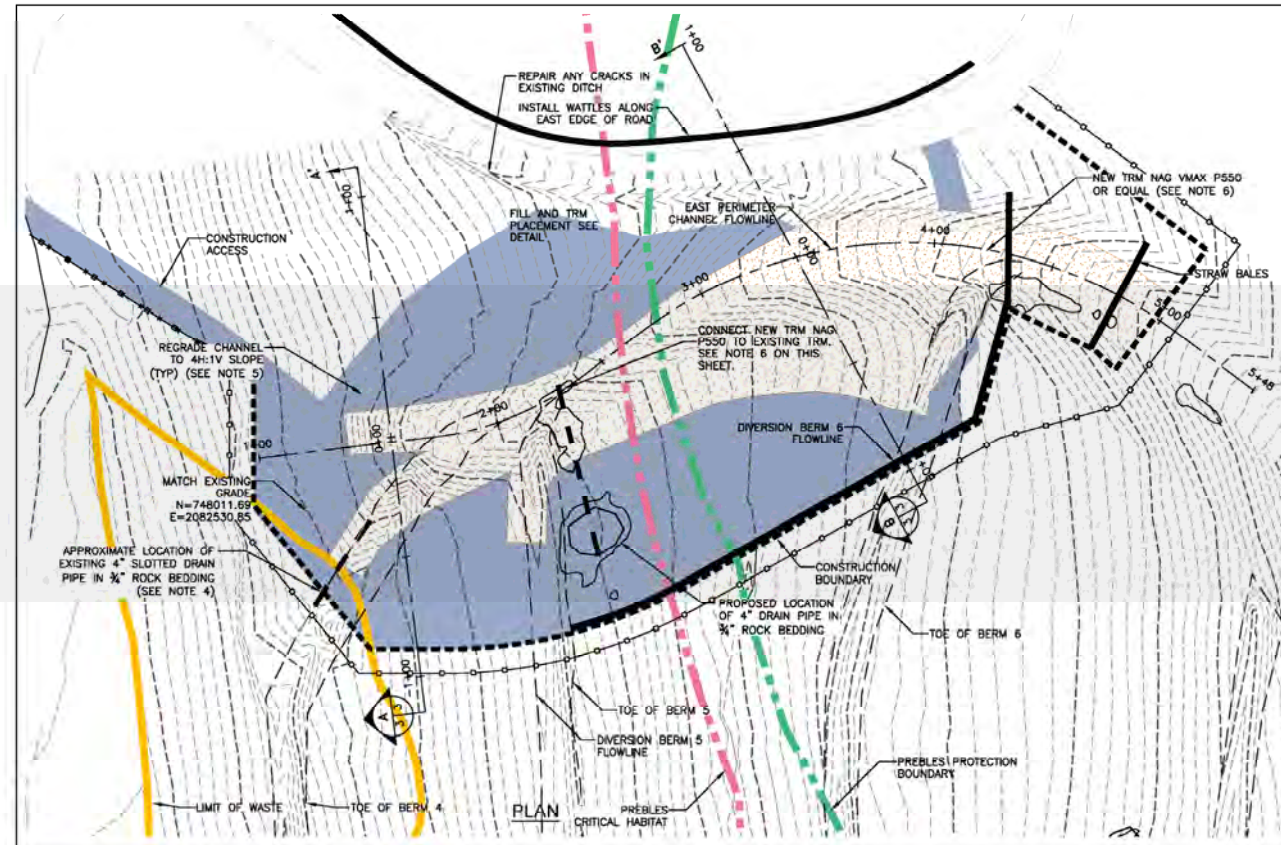

EARTHWORK QUANTITIES		
CUT	FILL	NET
1658 CU. YDS.	219 CU. YDS	1439 CU. YDS. <CUT>

NOTE: QUANTITIES ARE IN-PLACE AND DO NOT REFLECT SHRINK OR SWELL.

- NOTES:
1. TOPOGRAPHY BASED ON 6/12/2014 SITE SURVEY.
 2. WASTE BOUNDARY FROM .DWG FILE FROM ORIGINAL CONSTRUCTION DRAWINGS (FIGURE 3-1) BY EARTH TECH.
 3. EXCESS CUT SOIL SHALL BE HAULED TO LOCATION DIRECTED BY CONTRACTOR.
 4. PROTECT 4" SLOTTED DRAIN PIPE IN 3/4" ROCK BEDDING.
 5. REGRADE HEADWALL AND SURROUNDING AREA TO SLOPES FLATTER THAN 4H:1V.
 6. EXISTING TRM NAG VMAX P550 TO BE REMOVED PRIOR TO EARTHWORK AND REPLACED FOLLOWING GRADING ACCEPTANCE BY THE CONTRACTOR. (REUSE EXISTING TRM AS DIRECTED BY THE CONTRACTOR).
 7. THE HYDRAULIC CAPACITY OF THE EAST PERIMETER CHANNEL EXCEEDS THE COMBINED RUNOFF FOR THE 1,000 YEAR STORM EVENT OF DIVERSION BERMS 4,5,6, AND 7.
 8. PLACE FILL IN MAXIMUM 4" LOOSE LIFTS AND COMPACT WITH MINIMUM 4 PASSES OF A CATERPILLAR D-6 BULLDOZER OR EQUIVALENT COMPACTIVE EFFORT USING ALTERNATE EQUIPMENT AS APPROVED BY CONTRACTOR.
 9. FILL SHALL BE SUITABLE ON SITE MATERIALS FREE OF ORGANICS OR OTHER DELETERIOUS MATERIALS, OR IMPORTED SOILS MEETING CDOT CLASS 2 STRUCTURAL FILL REQUIREMENTS APPROVED BY THE CONTRACTOR.
 10. MOISTURE CONTENT OF FILL SHALL BE APPROPRIATE AS DETERMINED BY THE CONTRACTOR.

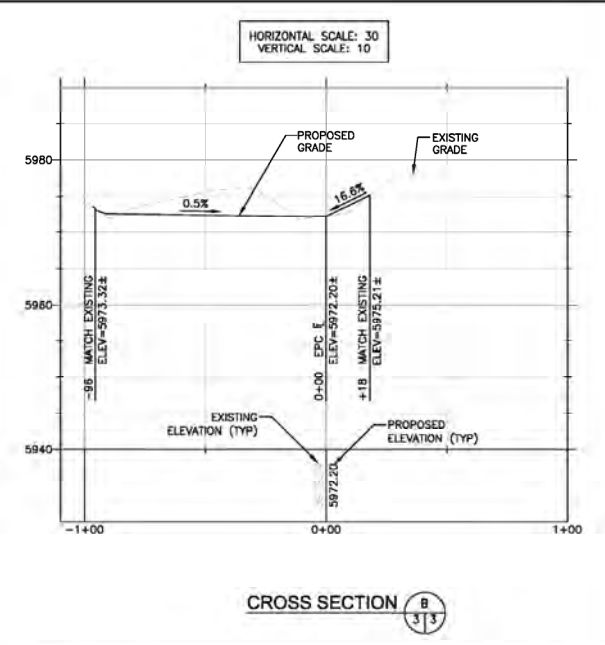
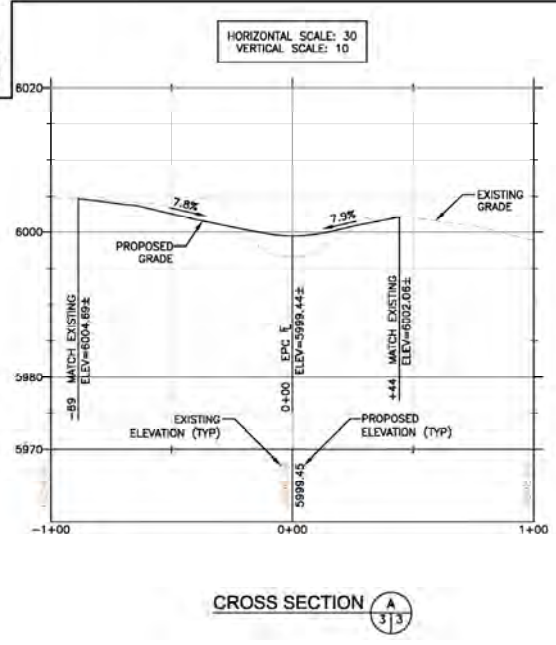
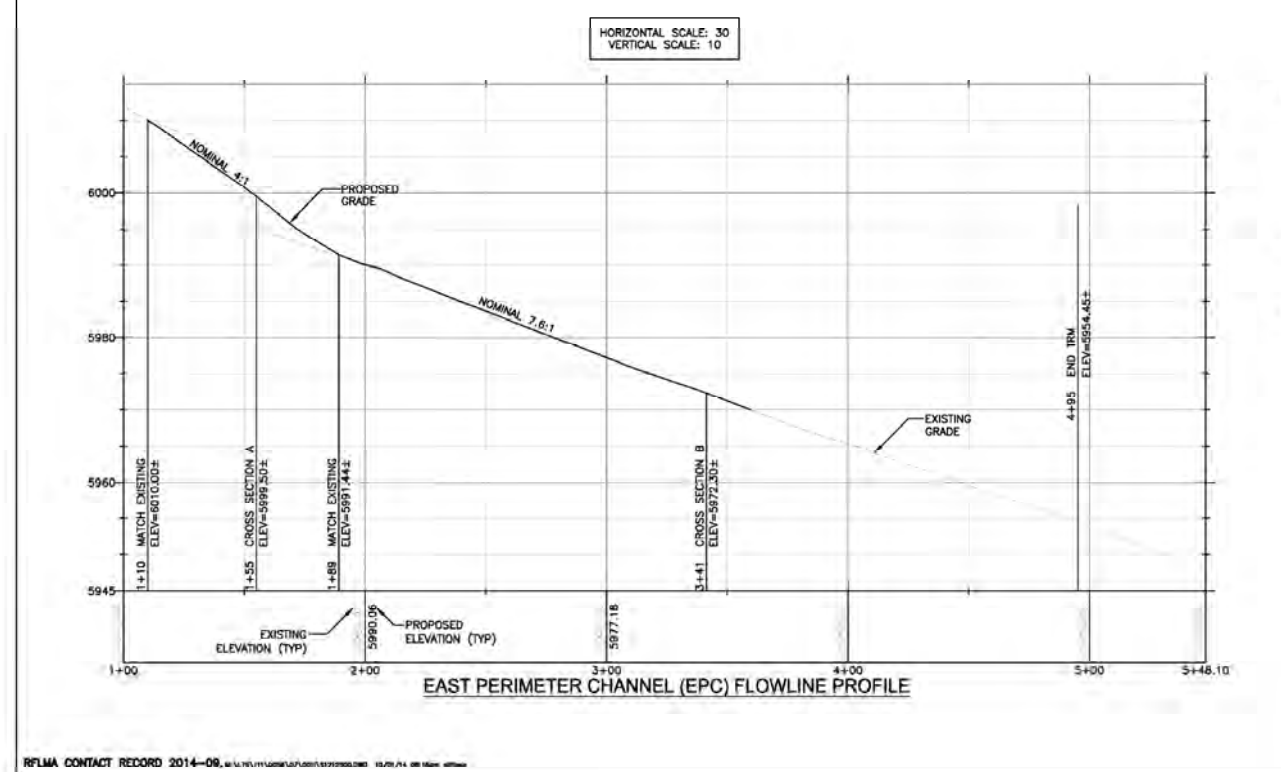
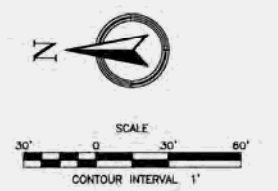

GENERAL PROJECT NOTES:
 PLOTTING OR PRINTING OF THESE DRAWINGS TO ANY SHEET SIZE OTHER THAN 24x36 OR BY USING FORMATS OTHER THAN AUTOCAD PLOT FILES WILL RESULT IN INCORRECT SCALES AND HATCH PATTERN DISTORTIONS. THE USER IS CAUTIONED AND SHOULD EITHER OBTAIN A HARD COPY PRINT-OUT FROM THE CONTRACTOR OR APPROPRIATELY SCALE ALL MEASUREMENTS FROM THE BAR-SCALES PROVIDED.

U.S. DEPARTMENT OF ENERGY GRAND JUNCTION, COLORADO ROCKY FLATS SITE JEFFERSON COUNTY, CO.		Work Performed by S.M. Stoller Corporation Under DOE Contract No. DE-LM0000415 ORIGINAL LANDFILL OLF SOIL DISTURBANCE FIGURE 1 FILLING AND GRADING LOCATION UPDATE LTS-111-0056-07-0011 512125-P01-800-D1	
APPROVALS MARIO HERRANZ 9/18/14 TOM CHAPEL 9/18/14 STEPHEN FITTON 9/22/14 MELISSA WAGNER 9/22/14 LINDA KAISER 9/22/14 LINDA KAISER 9/22/14	APPROVALS 9/18/14 9/18/14 9/22/14 9/22/14 9/22/14	1 1	1 1

Figure 1. OLF Soil Disturbance, Filling, and Grading Location



Figure 2 Soil Distribution Locations

Rocky Flats Legacy Management Agreement (RFLMA) Soil Disturbance Review Plan

Proposed Project: Soil Disturbance Review Plan (SDRP) Update for Regrading the East Perimeter Channel (EPC) and Associated Diversion Berms at the Original Landfill (OLF)

This SDRP provides information required by RFLMA Attachment 2, "Legacy Management Requirements," Section 4.1, "Soil Disturbance Review Plan," regarding the work proposed by DOE.

Description of the proposed project, including the purpose, the location, and the lateral and vertical extent of excavation.

The purpose of the proposed project is to regrade the EPC and associated diversion berm ends to reduce slope grades in this area to improve slope stability, and to add drainage features to further minimize the potential for infiltration of precipitation.

Contact Record 2014-09 Figure 1 shows the location and the lateral and vertical extent of the excavation and soil disturbance. The slopes of the western side of the EPC between berms 5 and 6 will not be restored to the existing grade, therefore reducing or removing the 2-foot soil cover; however, this area is outside the "limit of waste." The soil disturbance, regrading, and drainage feature installation work will not change the 2-foot-thick soil cover within the limits of the buried wastes. The material (Rocky Flats Alluvium) excavated from the cut areas will be used as fill in the fill areas. The excess soil will be distributed at designated locations in the COU as shown in Contact Record 2014-09 Figure 2.

Information about any remaining subsurface structures in the vicinity of the proposed project (or state that there are none if that is the case).

There are no remaining subsurface structures in the vicinity of the proposed project. A buried natural gas line operated by Xcel Energy is in the utility easement corridor north of the OLF. The location and alignment of the natural gas line is well known and marked with signs. It is well outside of the soil disturbance area.

Information about any former Individual Hazardous Substance Sites (IHSSs), Potential Areas of Concern, or other known or potential soil or groundwater contamination in the vicinity of the proposed project.

The OLF is former IHSS 115. The OLF has a 2-foot-thick soil cover over the location of the disposed waste materials and clean Rocky Flats Alluvium fill surrounding the waste materials for the placement and configuration of storm water and seep water management features. Limits of the waste area are shown in Contact Record 2014-09 Figure 1.

The project area is in the Upper Woman Drainage Exposure Unit (EU) evaluated in the Comprehensive Risk Assessment, Appendix A of the Remedial Investigation/Feasibility Study. The only contaminants of concern (COCs) identified for this EU are benzo[*a*]pyrene and dioxins/furans for surface soil/surface sediment. (currently buried several feet beneath the OLF cover).

Dioxin/furan concentrations were converted to 2,3,7,8-tetrachlorodibenzo-*p*-dioxin (TCDD) toxicity equivalents (TEQs) for COC screening and risk characterization. Noncancer risks for benzo[*a*]pyrene and 2,3,7,8-TCDD (TEQ) were not evaluated because those COCs do not have noncancer toxicity values. Risks were calculated for benzo[*a*]pyrene and 2,3,7,8 TCDD (TEQ). The estimated Tier 1 total excess lifetime cancer risk to the wildlife refuge worker (WRW) at the EU is 8E-06, and the Tier 2 risk is 4E-06. It is important to note that the samples with the highest benzo[*a*]pyrene concentrations are located in an area that is now several feet beneath OLF cover.

ROCKY FLATS SITE

REGULATORY CONTACT RECORD 2015-01

Purpose: Reportable condition for uranium 12-month rolling average at Point of Compliance WALPOC (this Contact Record supersedes RFLMA CR 2014-10)

Contact Record Approval Date: January 14, 2015

Site Contact(s)/Affiliation(s): Scott Surovchak, U.S. Department of Energy (DOE); George Squibb, Linda Kaiser, David Ward, Stoller Newport News Nuclear, Inc., (SN3), a wholly owned subsidiary of Huntington Ingalls Industries, Inc.

Regulatory Contact(s)/Affiliation(s): Carl Spreng, Colorado Department of Public Health and Environment (CDPHE); Vera Moritz, U.S. Environmental Protection Agency (EPA)

Dates of Consultation Meetings: November 19, 2014; January 5, 2015; January 7, 2015

Consultation Meetings Participants: Carl Spreng, CDPHE; Scott Surovchak, DOE; George Squibb, John Boylan, Jeremiah McLaughlin, David Ward, Linda Kaiser, SN3; Jody Nelson, J.G. Management Systems, Inc.

Discussion: A reportable condition is expected to occur at surface water Point of Compliance (POC) WALPOC at the Rocky Flats Site, Colorado, for the period from November 1, 2013, through October 31, 2014. The automated composite sample for the period October 23–31, 2014, was not retrieved from the field until January 6, 2015, because the collected sample volume in the carboy is not of sufficient quantity for analysis. However, available data show that the *Rocky Flats Legacy Management Agreement* (RFLMA) Attachment 2, Table 1, standard for uranium of 16.8 micrograms per liter ($\mu\text{g/L}$) will be exceeded when the final analytical results are received, regardless of the uranium concentration of the final sample. An evaluation of all available analytical results for uranium from composite samples and flow volume resulted in a calculated 12-month rolling anticipated average concentration for uranium of 17.2 $\mu\text{g/L}$ on October 31, 2014. This result exceeds the RFLMA Attachment 2, Table 1, standard for uranium of 16.8 $\mu\text{g/L}$, triggering an RFLMA reportable condition. The evaluation was performed in accordance with RFLMA Attachment 2, Figure 5, and “Points of Compliance.”

Representatives of CDPHE and DOE met on November 19, 2014, to discuss this result and develop a path forward. The RFLMA Parties agreed that the available data justified not waiting for validated results from the composite sample collected during the period of October 23–31 to start the 15-day clock specified in RFLMA Attachment 2, Figure 5, to issue the notification to regulatory agencies and the public. Therefore the required notification to the regulatory agencies and the public will be issued by December 4, 2014. (The required RFLMA notice was issued on December 3, 2014.)

Pursuant to RFLMA Attachment 2, Section 6.0, "Action Determinations," a reportable condition necessitates the following actions:

- DOE must submit a plan and schedule for an evaluation to address the condition within 30 days of receiving the validated data for the reportable condition.
- DOE will consult with CDPHE and EPA to determine if mitigating actions are necessary.
- The objective of the consultation will be to determine a course of action (if necessary) to address the reportable condition and to ensure that the remedy remains protective.
- The results of the consultation will be documented in contact records, in written correspondence, or both.

This contact record documents DOE's consultation with CDPHE on November 19, 2014, and subsequent consultations on January 5, 2015, and January 7, 2015.

The RFLMA Parties agreed that further evaluation should be completed to aid in developing future mitigating actions if they become necessary. The RFLMA Parties also agreed no mitigating actions are necessary at this time. The relevant factors evaluated in making this determination include the following:

- Preliminary results from the ongoing geochemistry study, referenced in Contact Record (CR) 2014-05 ("Reportable condition for evaluation purposes for uranium at Point of Compliance WALPOC," dated April 8, 2014), indicate that the increases in the 30-day rolling average uranium concentrations at WALPOC were caused by the September 2013 100-plus-year flood event, and will eventually return to below the 16.8 µg/L concentration. This projected decrease in uranium concentrations at WALPOC did occur in May 2014, when the 30-day average and composite samples concentrations dropped below 16.8 µg/L (see Attachment 1).
- WALPOC has been a RFLMA monitoring location for roughly 3 years. According to precipitation data collected across the Rocky Flats site since 1990, over the course of that 3-year period the Site experienced one of its driest years (2012) and its wettest month (September 2013). Because uranium concentrations are influenced by changing environmental conditions, varying uranium concentrations at WALPOC are anticipated. While significant uranium concentration variability can be seen in individual sample results as well as in the 30-day and 12-month averages, the observed variability is not outside of anticipated ranges nor do these levels suggest the existence of a new source term.
- Although the forecasted 17.2 µg/L result will be above the Site standard of 16.8 µg/L, it remains well below the drinking water standard (i.e., the maximum contaminant level [MCL]) of 30 µg/L. The 30 µg/L was determined to be an acceptable level of uranium in public water supplies by EPA in 2000 and adopted by the State of Colorado in 2005 as the statewide stream standard. Therefore, because the forecasted result remains below the 30 µg/L drinking water standard, the remedy remains protective of the downstream water uses.

Plan and Schedule to Address the Reportable Condition: The RFLMA Parties agreed that steps described in this contact record shall serve as the plan and schedule for the evaluation.

The following steps were, or will be, taken to inform the evaluation:

- Several samples were collected from WALPOC and other Walnut Creek locations and were analyzed using high-resolution methods to determine the isotopic uranium distribution. Many of these samples were collected as part of the RFLMA CR 2014-05 reportable action plan and included multiple post-flood WALPOC samples that were compared with historical data. Analytical results confirmed the uranium reported at WALPOC includes both naturally occurring and anthropogenic uranium. These samples included a split from the December 18, 2013, composite sample that triggered the earlier reportable 30-day average condition. Samples were also collected at Pond A-4, GS11 (Pond A-4 outlet), Pond B-5, and GS08 (Pond B-5 outlet) for high-resolution analysis. The isotopic results show that before the September 2013 storm, the uranium reported at WALPOC ranged from 76 to 80 percent natural; following this storm, the uranium at WALPOC was between 75 and 82 percent natural. These results do not indicate a significant shift in the uranium signature related to the heavy precipitation, nor do they suggest the existence of a new source term.
- The information in the geochemistry study identified in CR 2014-05 will be utilized as part of the evaluation of this current WALPOC reportable condition.

The purpose of this study, as it relates to this reportable condition, is to evaluate variability in uranium concentrations—due to seasonal, hydrologic, geochemical, and geographic effects—through the collection of targeted analytical and field data. The study also incorporates the ongoing calculation of the percentages of natural uranium versus anthropogenic uranium in Walnut Creek.

- Split samples will continue to be collected from each flow-paced composite collected at WALPOC and held for possible high-resolution isotopic uranium analysis.
- Additional, recently collected split samples from WALPOC will be submitted for high-resolution isotopic uranium analysis to determine if the natural uranium concentrations have changed now that the effects of the September 2013 event have waned.
- Flow-paced composite samples routinely being collected at WALPOC will continue to be analyzed on a 2-week turnaround.
- Additional actions may be implemented as appropriate based on the data gathered from the above evaluations.

DOE will report the results of this monitoring and of the subsequent evaluation in RFLMA quarterly and annual reports of surveillance and monitoring activities. This plan and schedule may be modified based on the outcome of RFLMA Party consultation related to the evaluation.

To keep the public informed, the outcome of continuing RFLMA Party consultation regarding the evaluation will be reported in RFLMA quarterly and annual reports of surveillance and monitoring activities or in subsequent contact records.

Resolution: Carl Spreng, CDPHE, has approved this contact record.

Closeout of Contact Record: This contact record will be closed when the results from the evaluation have been transmitted to CDPHE, or as the RFLMA Party consultation related to this evaluation directs.

Contact Record Prepared by: David Ward, George Squibb, and John Boylan, SN3

Distribution:

Carl Spreng, CDPHE

Scott Surovchak, DOE

Vera Moritz, EPA

Linda Kaiser, SN3

Rocky Flats Contact Record File

POC Gaging Station WALPOC: Total Uranium Water Quality (9/12/11 - 10/22/14)

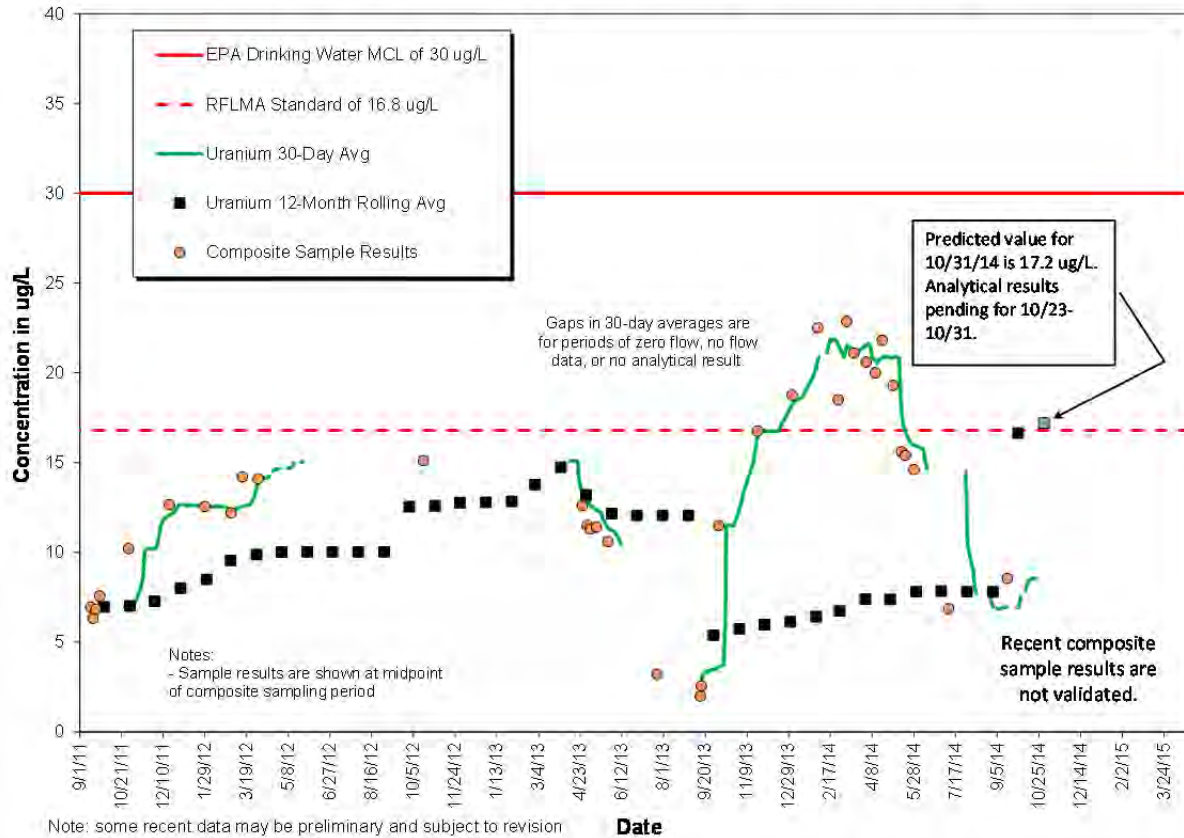

Attachment 1

ROCKY FLATS SITE REGULATORY CONTACT RECORD 2015-02

Purpose: Soil Disturbance Review Plan (SDRP) for Storage Shed Photovoltaic Upgrades

Contact Record Approval Date: April 25, 2015

Site Contact(s)/Affiliation(s): Scott Surovchak, U.S. Department of Energy (DOE); Kurt Franzen, Linda Kaiser, David Ward, Stoller Newport News Nuclear, Inc. (SN3), a wholly owned subsidiary of Huntington Ingalls Industries, Inc.

Regulatory Contact(s)/Affiliation(s): Carl Spreng, Colorado Department of Public Health and Environment (CDPHE); Vera Moritz, U.S. Environmental Protection Agency (EPA)

Introduction: This Contact Record concerns proposed upgrades to a storage shed that was constructed around 2001 at the Rocky Flats, Colorado, Site. The shed is on a concrete slab floor, with structural steel wall frames and roof trusses, rigid sidewall, and galvanized metal roofing and siding. A photovoltaic (PV) system at the storage shed provides power to operate overhead garage-doors motors and small LED emergency lights. The PV system operates with an inverter.

Discussion: The storage shed photovoltaic upgrade project is designed to provide sufficient additional power at the shed to power the existing overhead garage doors, the existing LED lighting, and additional powered hand tools. The existing system shall be evaluated for reusing as much of the existing equipment as possible. The required new PV panels will rest on supports, including the one existing support. The new supports will require 12-inch diameter holes drilled approximately 3 feet deep. The holes will be filled with concrete. The supports will be in an 8-foot by 16-foot (approximate) array with the existing support on the east side of the array.

The soil disturbance that occurs during the excavation of the holes for the support of the new PV panels is subject to the requirements of certain *Rocky Flats Legacy Management Agreement* (RFLMA) institutional controls (ICs), as discussed below. An approved SDRP is required and the RFLMA parties agree that Figure 1 provides sufficient information for the SDRP for the proposed work.

Institutional Controls Evaluation: The soil disturbance work is subject to IC 2. Table 1 recaps this IC.

Table 1. Institutional Controls

Controls	Use Restrictions
2	Excavation, drilling, and other intrusive activities below a depth of three feet are prohibited, without prior regulatory review and approval pursuant to the Soil Disturbance Review Plan in RFLMA Attachment 2.
	<p>Objective: Prevent unacceptable exposure to residual subsurface contamination.</p> <p>Rationale: Contaminated structures, such as building basements, exist in certain areas of the Central Operating Unit, and the Comprehensive Risk Assessment did not evaluate the risks posed by exposure to this residual contamination. Thus, this restriction eliminates the possibility of unacceptable exposures. Additionally, it prevents damage to subsurface engineered components of the remedy.</p>

The required SDRP is in Attachment 1.

Resolution: CDPHE has review information regarding the proposed soil disturbance and excavation and, after consulting with EPA, has approved the proposed activity and the proposed grading plan. CDPHE has determined that the proposed activity will not compromise or impair the function of the remedy or result in an unacceptable release or exposure to residual subsurface contamination. CDPHE has also determined that the proposed project meets the rationale and objectives of IC 2.

The work will be conducted after CDPHE's approval, but DOE will not conduct the approved soil disturbance until 10 calendar days after this Contact Record is posted on the Rocky Flats site's website and stakeholders are notified of the posting in accordance with the RFLMA Public Involvement Plan. The work is planned to be conducted and completed in the spring of 2015.

Information regarding the drilling of these support footings will be reported in quarterly reports, annual reports, or both, depending on when the activities occur.

Closeout of Contact Record: This contact record will be closed when the new supports are installed, the excavation is backfilled, and any revegetation and erosion controls are in place.

Contact Record Prepared by: David Ward

Distribution:

Carl Spreng, CDPHE
Scott Surovchak, DOE
Vera Moritz, EPA
Linda Kaiser, SN3
Rocky Flats Contact Record File

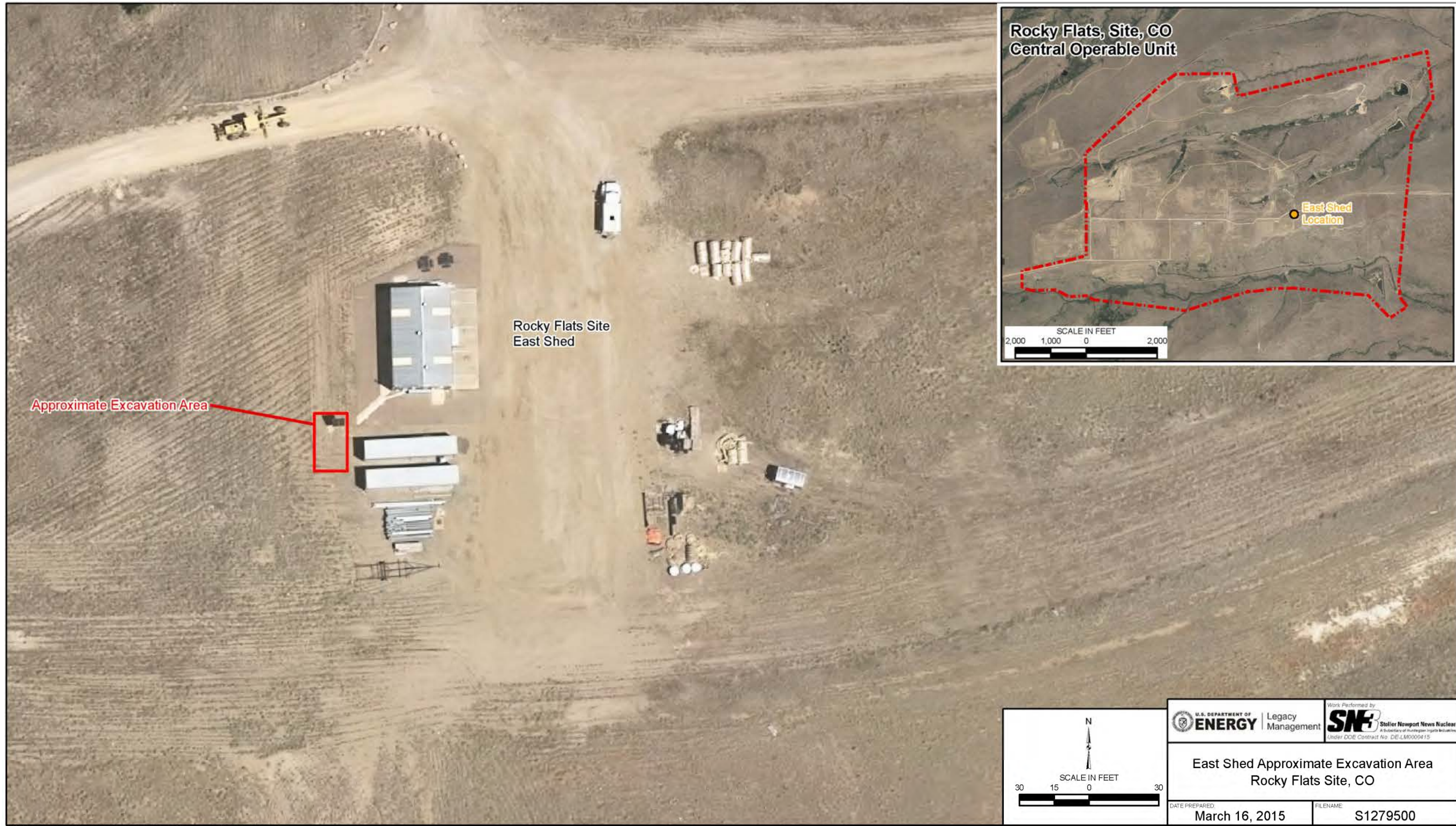

Figure 1. Location of Excavation for Storage Shed PV Upgrades Project

Attachment 1

Rocky Flats Legacy Management Agreement (RFLMA) Soil Disturbance Review Plan (SDRP)

Proposed Project: SDRP for Storage Shed Photovoltaic Upgrades

This SDRP provides information required by RFLMA Attachment 2, “Legacy Management Requirements,” Section 4.1, “Soil Disturbance Review Plan,” regarding the work proposed by DOE.

(1) Description of the proposed project, including the purpose, the location, and the lateral and vertical extent of excavation.

The purpose of the project is to provide additional power to a storage shed (formerly known as building 920B) for operating additional hand tools. Additional photovoltaic (PV) panels are required to provide the additional power.

Holes, 12-inches in diameter and approximately 3 feet deep, will be drilled and filled with concrete. The additional PV panels will be supported by the new concrete footings. Figure 1 in Contact Record 2015-02 shows the approximate location of the new supports.

(2) Information about any remaining subsurface structures in the vicinity of the proposed project.

The shed was a vehicle inspection building (formerly known as Building 920B) for the east gate. There are no subsurface structures in the vicinity of this project.

(3) Information about any former Individual Hazardous Substance Sites (IHSSs), Potential Areas of Concern (PACs), or other known or potential soil or groundwater contamination in the vicinity of the proposed project.

No IHSSs were identified in the project area.

(4) Resurvey any new surface established in subsurface soil, unless sufficient existing data is available to characterize the surface (or state that the excavated soil will be replaced and the original contours restored).

The holes will be filled with concrete and the surrounding surface will be returned to the existing grade. Therefore, the original contours will be restored.

ROCKY FLATS SITE

REGULATORY CONTACT RECORD 2015-03

Purpose: Original Landfill (OLF) Immediate Response to Recent Precipitation

Contact Record Approval Date: May 26, 2015

Site Contact(s)/Affiliation(s): Scott Surovchak, U.S. Department of Energy (DOE); Kurt Franzen, Linda Kaiser, David Ward, Stoller Newport News Nuclear, Inc. (SN3), a wholly owned subsidiary of Huntington Ingalls Industries, Inc.

Regulatory Contact(s)/Affiliation(s): Carl Spreng, Colorado Department of Public Health and Environment (CDPHE); Vera Moritz, U.S. Environmental Protection Agency (EPA)

Date of Consultation Meeting: May 13 and 14, 2015

Consultation Meeting Participants: Carl Spreng, CDHPE; Scott Surovchak, DOE; Kurt Franzen, SN3; David Ward, SN3, John Boylan, SN3

Introduction: The past several weeks of precipitation events have led to unusually high groundwater volumes that, in turn, have caused portions of the Original Landfill (OLF)—particularly in the area of the East Perimeter Channel (EPC)—to subside. This movement is evident over daily to weekly periods and is appearing as surficial cracks, settling (depressions), or rotational slumping. Repairs that have been completed on these features have needed to be repeated multiple times because the ground surface continues to move. These repairs have not been able to keep up with the recent movements.

Since the movement is being caused by excessive groundwater, it is necessary to improve control of this moisture. Action is urgently needed to drain and divert as much surface water and groundwater as possible away from the eastern edge of the OLF cover and the EPC. The pre-existing subsurface drain in this area appears to have been compromised, based on the presence here of seeps and pools on the surface. Therefore, this action may include drilling or digging holes greater than 3 feet deep to locate and intersect the groundwater and this drain, repairing and potentially reconfiguring this drain, and then diverting the water away from the OLF cover and EPC.

Localized instability of the EPC first occurred as the result of the rain event from September 9 through September 16, 2013, and was identified as a reportable condition in Contact Record 2013-02, dated September 18, 2013. The efforts to repair, reconfigure, and stabilize the EPC that are listed in Contact Record 2013-03 and modified in Contact Record 2014-09 were completed in January 2015. Since that time the Site has received over 11 inches of precipitation and movement of the ground surface in this area has resumed.

Although the effort to correct the EPC is an ongoing, reportable condition, its current status requires immediate action. CDPHE was notified on May 13, 2015, of the potential need to

RFLMA Contact Record 2015-03

excavate holes greater than 3 feet deep in order to investigate the subsurface drain and dewater the area. CDPHE and DOE walk down the OLF on May 14, 2015, and agreed this action is an immediate need to dewater and stabilize the EPC and the eastern portion of the OLF cover.

Rocky Flats Legacy Management Agreement (RFLMA), Attachment 2, Section 4.0, “Institutional Controls,” provides that “Except for situations where immediate action is warranted, DOE will not implement the activity for which the regulatory determination is required until 10 calendar days after the contact record or written correspondence approving the activity is posted on the Rocky Flats website and notification of the posting is made to stakeholders in accordance with the RFLMA Public Involvement Plan.”

Discussion: During the walk down on May 14, 2015, of the EPC and OLF cover, representatives of the DOE and CDPHE determined that immediate action is warranted to get the water off of, or out of, the EPC and OLF cover. To achieve this, it would be appropriate to start excavating to depths greater than 3 feet deep to locate and intercept the groundwater and subsurface drain as soon as practicable and not wait 10 days after posting of a contact record. The area is currently saturated. A third-party geotechnical engineer with extensive knowledge of the OLF is currently evaluating where and how deep to dig. One or more localized subsurface drains may be added. Longer-term actions are also being evaluated.

Efforts are already underway to drain the surface water off the face of the OLF cover with shallow trenching and flexible piping. The sampling of the RCRA wells in the vicinity of the OLF was completed recently and the results will be available in June. The surface water monitoring location downstream of the OLF in Woman Creek (GS59) was collected as a composite sample in a carboy. The last carboy, which covers the period from May 9 to May 18, was collected on May 18, 2015. These results will also be available in June.

The *Original Landfill Monitoring and Maintenance Plan*, Section 6.0, “Reporting and Contact Information,” requires “DOE will follow RFLMA requirements for reportable conditions, and potentially impacted communities will be notified immediately of conditions that occur at any time that require immediate attention.” The potentially impacted communities were notified on May 14, 2015, of the need to take immediate action with the EPC and OLF cover.

Resolution: CDPHE agrees with the need to take immediate action to remove surface water and groundwater from the EPC and the OLF. DOE has started surface water removal and is preparing to intercept groundwater as soon as practicable.

Any interim or long term plans for addressing the EPC and the OLF cover that require a regulatory determination, and is not immediate action, will be documented in a later contact record posted on the Rocky Flats webpage as required by the RFLMA process.

Progress of this work will be reported by DOE in RFLMA quarterly and annual reports of surveillance and maintenance activities for the period(s) in which these activities occur.

Closeout of Contact Record: This Contact Record will be closed when the work is completed, post-construction reseeding has been performed, and post-construction erosion controls are in place.

Contact Record Prepared by: David Ward

RFLMA Contact Record 2015-03

Distribution:

Carl Spreng, CDPHE

Vera Moritz, EPA

Scott Surovchak, DOE

Linda Kaiser, SN3

Rocky Flats Contact Record File